



**YOUR**  
**OUTDOOR COOKING**

**outdoor cooking  
collection**

**stainless steel  
cooktop**

**italian-made**

# PADELLA

# FRY TOP

# TEPPANYAKI

# PLANCHA

---

# PIANO COTTURA

# PLA.NET

Called Plancha in Spain and France or Teppanyaki in Japan, the PLA.NET cooking top is not just a traditional barbecue, rather it's a stainless steel surface that runs on gas or electricity; it reaches high temperatures quickly, allowing for healthy and tasty cooking, without making any smoke and respecting the environment.

Chiamata Plancha in Spagna e Francia o Teppanyaki in Giappone, il piano di cottura PLA.NET non è un barbecue tradizionale ma una superficie in acciaio inox funzionante a gas o energia elettrica, va in temperatura velocemente, consentendo una cottura sana e gustosa, senza fumo e nel rispetto dell'ambiente.

**PADELLA:** usata ovunque in cucina, domestica o ristorante, spesso rivestita con teflon, non è altro che un piano, con bordi rialzati, che una volta riscaldato dal fuoco sottostante, consente la cottura di svariati tipi di cibo.

PAN: used practically everywhere in the kitchen, whether domestic or restaurant, often covered with Teflon; it is nothing more than a countertop, with raised edges, which once heated, allows you to cook various types of food.



**TEPPANYAKI:** sistema cottura di origine giapponese (teppan= piastra e yaki= grigliare). Diffusa nel mondo (a New York dal 1964), teppanyaki è anche diventato sinonimo di prodotto, piccola piastra elettrica inserita in cucina, affiancata ai fornelli.

TEPPANYAKI: a cooking system of Japanese origin (teppan= hot plate and yaki= to grill). Widespread throughout the world (in New York since 1964), teppanyaki has also become synonymous of a product, small electric plate placed in the kitchen along with the stove.



**PLANCHA:** termine spagnolo, usato anche in Francia, che significa piastra. Realizzata in vari materiali, riscaldata col fuoco, viene utilizzata per cotture all'esterno. Proposta anche dai produttori di cucine per la casa, per usarla come piano cottura sopra i fornelli, sfruttando questa fonte di calore, per cucinare "alla piastra".

PLANCHA: Spanish term, also used in France, which means hot plate. Made of various materials, heated by fire, it is used for outdoor cooking. Also offered by home kitchen manufacturers to use as a hob above the stove, taking advantage of the heat source to cook as a "hot plate".



**FRY TOP:** identifica un piano cottura in acciaio, usato nella ristorazione professionale (ristoranti, catering, mense) o street food (furgoni attrezzati, chioschi), in tutto il mondo. Garantisce cottura rapida e igienica di pesce, molluschi, carne, verdure, prodotti vegani, ma anche hot dog, panini, eggs and bacon, crêpe.

FRY TOP: a steel hob used in professional kitchens (restaurants, catering services, canteens) or street food (equipped vans, kiosks), all over the world. It guarantees quick and hygienic cooking of fish, shellfish, meat, vegetables, vegan products, but also hot dogs, sandwiches, eggs and bacon, crêpe.

## PROJECT PLA.NET

Progetto che sintetizza storia, esperienze culinarie, professionalità, moderne tecnologie e materiali, per godere dei vantaggi di questi sistemi di cottura all'esterno, a casa propria, tutti i giorni dell'anno.

A project that summarizes history, culinary experiences, professionalism, modern technologies and materials, so as to enjoy the advantages of these outdoor cooking systems, at home, every day of the year.

\* **PUOI** cucinare all'aria aperta comodo come fossi dentro casa e in sicurezza;

\* **UN** piano cottura come un FRY TOP: materiale alimentare, igienico e pulibile, con tempi di cottura anche brevissimi;

\* **PUOI** cucinare di tutto: pesce e molluschi, carne, verdure, vegano e poter fare colazione, pranzo, cena, per 365 giorni l'anno;

\* **PUOI** trovare soluzioni e misure giuste per le tue esigenze domestiche, pratico come una PLANCHA;

\* **UN** prodotto semplice, facile da usare come cucinare su una PADELLA;

\* **PUOI** stare in compagnia mentre cucini, come nel TEPPANYAKI.

\* **YOU CAN** cook at open air comfortably as if you were inside your home and in complete safety;

\* a hob like a FRY TOP: food material, hygienic and cleanable, with very short cooking times;

\* **YOU CAN** cook anything: fish and shellfish, meat, vegetables, vegan products and prepare breakfast, lunch or dinner, 365 days a year;

\* **YOU CAN** find the right solutions and measures for your domestic needs, practical like a PLANCHA;

\* a simple product, easy to use as if cooking with a PAN;

\* **YOU CAN** relax or entertain company while you cook, functional like a TEPPANYAKI.

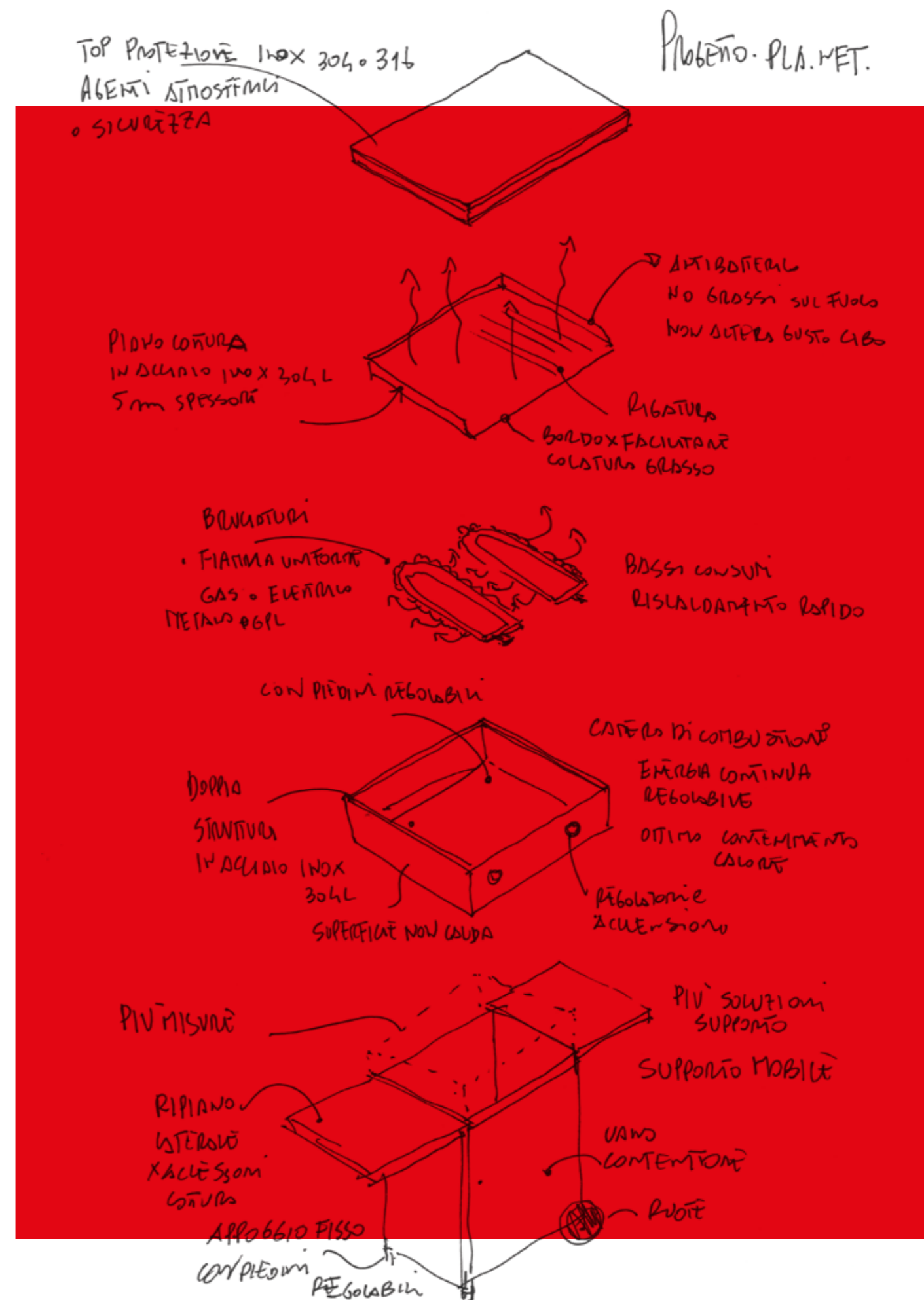



**S**  
SECURE

**L'adozione di soluzioni professionali, come la camera di combustione interna e struttura esterna separate (doppia struttura) che tiene il calore internamente, migliora le performance di cottura e soprattutto garantisce una bassa temperatura all'esterno evitando possibili ustioni per contatto accidentale dei bambini o di chi sta intorno al piano cottura.**

**EN** Adopting professional solutions, internal combustion chamber and separate external structure (double structure) that keeps the heat inside, improves the cooking performance and most of all guarantees a low temperature externally thus avoiding possible burns if accidentally touched by children or those standing around the hob.  
**FR** L'adoption de solutions professionnelles, chambre de combustion interne et structure professionnelle externe séparée (double structure) qui garde la chaleur à l'intérieur, améliore les performances de cuisson et surtout garantit une basse température à l'extérieur tout en évitant de possibles brûlures par contact accidentel d'enfants ou de ceux qui sont autour du plan de cuisson.  
**DE** Die Umsetzung von professionellen Lösungen, interne Brennkammer und separate Außenstruktur (doppelte Struktur), welche die Wärme innen hält, verbessert die Kochleistung und gewährleistet vor allem eine niedrige Außentemperatur, sodass mögliche Verbrennungen durch ungewolltes Berühren von Kindern oder denjenigen vermieden wird, die sich in der Nähe der Kochplatte befinden.



**4**  
4 SEASON

**La doppia struttura, i materiali utilizzati e il sistema di funzionamento, permettono di regolare temperature e tempi di cottura anche rapidi, quindi un utilizzo del prodotto tutto l'anno, estate e inverno, in compagnia. Inoltre produce solo vapore del cibo che cuoce, (no grassi sul fuoco, fiammate e fumo) in sicurezza.**

**EN** The double structure, the materials used and the operating system allow you to regulate temperatures and cooking times (even quick); as a result, the product can be used all year round, summer and winter, in company. It also only produces steam from the food that cooks (no grease on the fire, flames and smoke) in total safety.  
**FR** La double structure, les matériaux utilisés et le système d'exploitation, permettent de régler les températures et les temps de cuisson même les rapides, et vous pouvez utiliser le produit toute l'année, été comme hiver, en compagnie. De plus, il ne produit que la vapeur la nourriture qui cuit, (pas de matières grasses sur le feu, les flammes et la fumée) en toute sécurité.  
**DE** Die doppelte Struktur, die verwendeten Materialien sowie das Betriebssystem ermöglichen, Temperaturen und auch schnelle Kochzeiten einzustellen, sodass das Produkt das ganze Jahr über, im Sommer und im Winter, in Gesellschaft verwendet werden kann. Darüber hinaus entsteht nur Dampf der kochenden Speisen (kein Fett auf der Flamme, Aufflammen und Rauch), und das in Sicherheit.



**N**  
NO SMOKE

**La cottura su un piano inclinato e la raccolta grassi in una bacinella, non permette ai grassi residui di cadere sul fuoco provocando fumo e fiammate sul cibo. Il gusto del cibo quindi non viene contaminato e conserva il suo sapore, inoltre non da fastidio ai vicini se usato sul terrazzo o balcone di casa.**

**EN** Cooking is carried out on a sloping surface and the grease is collected in a basin, a system that doesn't allow residual grease to fall on the fire causing smoke and flames on the food. The taste of the food is therefore not contaminated and retains its flavour; furthermore, it does not bother the neighbours if used on a terrace or balcony.  
**FR** La cuisson sur un plan incliné et la collecte les graisses dans un bassin, ne permet pas aux graisses résiduelles de tomber sur le feu en causant de la fumée et des flammes sur la nourriture. Le goût de la nourriture n'en est pas contaminé et préserve toute sa saveur, et ne dérange pas les voisins en cas d'utilisation sur la terrasse ou le balcon de la maison.  
**DE** Durch das Kochen auf einer geneigten Platte und das Auffangen des Fettes in einer Wanne kann das restliche Fett nicht auf die Flamme geraten und so Rauch und Feuerzungen auf den Speisen verursachen. Der Geschmack der Speisen wird dadurch nicht beeinträchtigt und behält das Aroma, außerdem werden die Nachbarn nicht belästigt, falls auf der Terrasse oder dem Balkon gekocht wird.



**T**  
TASTY

**Il piano unico di cottura e la possibilità di regolazione rapida della temperatura, consente di poter cuocere unità di cibo piccole e grandi (niente cade giù), qualsiasi tipo di cibo possa stare a contatto della piastra. L'acciaio inox inoltre non assorbe odori; è possibile quindi passare da cotture di pesce alla carne, verdure o altro, senza intaccare il gusto.**

**EN** The single cooking top and the quick temperature adjustment, allows you to cook both small and large food (nothing falls down). Any type of food can be cooked with the hot plate. Furthermore, stainless steel does not absorb odours; you can switch from cooking fish to meat, vegetables or other food, without affecting the taste.  
**FR** Le seul niveau de cuisson et la possibilité d'ajustement rapide de la température, vous permet de cuisiner des aliments en petites et grandes pièces (rien ne tombe vers le bas), tout type de nourriture pouvant rester en contact avec la plaque. De plus, l'acier inoxydable n'absorbe pas les odeurs ; vous pouvez alors passer de la cuisson du poisson à la viande, aux légumes ou à d'autres, sans affecter le goût.  
**DE** Die einzige Kochplatte und die Möglichkeit der schnellen Temperaturregelung erlaubt das Kochen von kleinen sowie großen Speisen (es fällt nichts herunter) und von jeglicher Speise, die mit der Platte in Berührung kommen darf. Der Edelstahl absorbiert außerdem keine Gerüche; es kann also vom Kochen von Fisch auf Fleisch, Gemüse oder Anderes übergegangen werden, ohne den Geschmack zu beeinträchtigen.



**A**  
ADAPT

**Svariate le dimensioni del piano cottura e la disponibilità di accessori (fornelli, friggitorici, lavelli, utensili cucina). Il piano cottura inoltre appoggia su piedini regolabili o può essere fissato su varie tipologie di carrelli, o anche incassato su piani esistenti in strutture progettate ad hoc. Possibile quindi un acquisto su misura, secondo proprio stile e personalità.**

**EN** The hob comes in numerous sizes and the accessories (cookers, fryers, sinks, kitchen utensils) are varied. The hob also rests on adjustable feet or can be fastened onto various types of trolleys, or even placed in existing kitchen units in custom-designed structures. Tailor-made purchases, according to your style and personality.  
**FR** Les dimensions de la table de cuisson et la disponibilité des accessoires (fourneaux, friteuses, évier, ustensiles de cuisine) sont variées. Le plan de cuisson repose également sur des pieds réglables ou peut être fixé sur divers types de chariots, ou même encastré dans des sols existants dans des structures conçues sur mesure. Un achat sur mesure est également possible en fonction de leur style et de leur personnalité.  
**DE** Verschiedene Abmessungen der Kochplatte und verfügbares Zubehör (Kochstellen, Fritteusen, Waschbecken, Küchenutensilien). Die Kochplatte steht außerdem auf einstellbaren Füßen oder kann auf verschiedene Wagentypen befestigt, oder auch auf bestehenden Flächen in Ad-hoc-Strukturen angesenkt werden. Somit kann ein Kauf nach Maß erfolgen, je nach eigenem Stil und Persönlichkeit.



**E**  
EASY

**Il sistema di cottura è ben noto (vedi padella o plancha o teppanyaki/fry top) e quindi alla portata di tutti. Non ha bisogno di lunghe preparazioni o attese di riscaldamento. Facile da pulire e non delicato trattandosi di acciaio inox.**

**EN** The cooking system is well known (see pan or plancha or teppanyaki/fry top) and therefore user-friendly for everyone. It doesn't require long preparation or heating times. It's easy to clean yet not delicate, because it is made of stainless steel.  
**FR** Le système de cuisson est bien connu (voir casserole ou plancha ou teppanyaki / fry top) et donc à la portée de tous. Nul besoin de longues préparations ni d'attentes de chauffage. Facile à nettoyer et pas délicat comme il s'agit d'acier inoxydable.  
**DE** Das Kochsystem ist gut bekannt (siehe Pfanne oder Plancha oder Teppanyaki/Fry Top) und somit für jedermann. Langes Vorbereiten oder Aufheizen ist nicht nötig. Leicht zu reinigen und unempfindlich, das es sich um Edelstahl handelt.





**MOMA**

**P.11-15**



**CHEF**

**P.17-21**



**ALFA**

**P.22-23**



**WATT**

**P.27-29**



**OASI**

**P.31-41**

**ACCESSORI**

**P.42-45**

**COMPANY**

**P.46-48**



# MOMA

FUNCTION DESIGN

Il design incontra la funzione

**Comandi nel piano inclinato superiore, per una migliore visione e gestione. Maggiore sicurezza riducendo la possibilità di incauto uso da parte dei bambini. La doppia struttura mantiene le basse temperature esterne e l'adozione del P.G.S (PLA.NET Gas Stop) chiude il gas se la fiamma dovesse spegnersi.**

**Accensione Piezoelettronica Integrata a impulso (PEO/I) ripetuto nella manopola. Piano cottura con riscaldamento decentrato, per ottenere cotture a bassa temperatura o per tenere in caldo il cibo già cotto: minore temperatura nella zona destra della piastra.**

**EN** The controls are found in the upper inclined surface for better vision and handling. Much safer due to reducing the possibility of careless use by children. The double structure maintains low external temperatures and the use of the P.G.S (PLA.NET Gas Stop) turns off the gas should the flame go out. Integrated Piezoelectric Starter with repeated impulse (PEO/I) on the knob. This hob has decentralized heating, for cooking at low temperatures or to keep cooked food warm: lower temperature is on the right side of the plate.

**FR** Commandes dans le plan incliné supérieur, pour une meilleure vision et gestion. Sécurité optimale en réduisant la possibilité de négligence utilisation par les enfants. La double structure maintient les basses températures externes et l'adoption du P.G.S (PLA.NET Gas Stop) ferme le gaz si la flamme devait s'éteindre. Allumage piézoélectronique intégré à impulsion répétée (PEO/I) dans le bouton. Plan de chute avec chauffage décentralisé, pour obtenir une cuisson à basse température ou pour maintenir au chaud les aliments déjà cuits: température plus basse dans la zone droite de plaque.

**DE** Bedienknöpfe an der oberen geneigten Abdeckung für bessere Sicht und Bedienung. Höhere Sicherheit durch verringerte Möglichkeit des unvorsichtigen Gebrauchs durch Kinder. Die doppelte Struktur behält die niedrigen Außentemperaturen bei, und das P.G.S (PLA.NET Gas Stop) unterbricht den Gasstrom, falls die Flamme erlöschen sollte. Integrierte Piezoelektrische Zündung mit wiederholtem Impuls (PEO/I) im Drehknopf. Kochfeld mit dezentraler Aufheizung, um das Garen bei niedriger Temperatur zu erhalten oder bereits gekochte Speisen warm zu halten: niedrigere Temperatur im rechten Bereich der Platte.



					S.S. / INOX
55T - 80T	GAS	AA 1,5V	PEO/I	P.G.S.	A 304L

# MOMA 55T



**A**

**Piastra Riscaldamento Differenziato: posizionamento disassato dei bruciatori per avere una zona a destra con più bassa temperatura, dove mantenere in temperatura il cibo cotto.**

Differentiated Hot Plate: offset positioning of the burners creating a section on the right with lower temperature, where to keep cooked food warm.

Plaque chauffage différenciée : positionnement désaxé des brûleurs pour avoir une zone à droite avec une température plus basse, où maintenir en température les aliments cuits.

Platte mit differenzierter Aufheizung: versetzte Position der Brenner, damit man einen Bereich rechts mit niedrigerer Temperatur hat, wo die gekochten Speisen warm gehalten werden können.

**B**

**Moma Control Panel: comandi su piano inclinato superiore. Migliore gestione comandi gas e sicurezza (riduzione possibilità incauto uso da parte dei bambini).**

Moma Control Panel: controls on upper inclined plane. Better handling of gas and safety controls (safer for children).

Panneau de configuration Moma : commandes sur le plan incliné supérieur. Meilleure gestion des commandes de gaz et de sécurité (réduction des possibilités imprudentes d'utilisation par les enfants).

Moma Control Panel: Bedienknöpfe an der oberen geneigten Abdeckung. Bessere Bedienung der Gasdrehknöpfe und Sicherheit (verringerte Möglichkeit des unvorsichtigen Gebrauchs durch Kinder).

**C**

**Planet Gas Stop: chiusura automatica del gas se per qualsiasi motivo la fiamma si spegne.**

Planet Gas Stop: automatic closure of the gas flow if for any reason the flame goes out.

Planet Gas Stop: fermeture automatique du gaz si, pour quelque raison que ce soit, la flamme s'éteint.

Planet Gas Stop: automatisches Abstellen des Gases, falls die Flamme aus irgendeinem Grund erlischt.

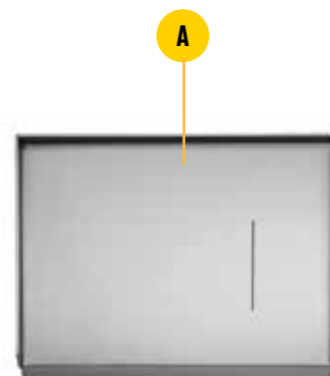

Art. 55T.L

**D**

**Accensione piezoelettronica a Ripetizione Integrata: premere e girare la manopola. Impulso automatico ripetuto.**

Integrated Repeating piezoelectric starter: press and turn the knob. Repeating automatic pulse.

Allumage piézoélectronique à répétition intégrée : appuyez et tournez le bouton. Impulsion automatique répétée.

Integrierte wiederholte Piezoelektrische Zündung: den Drehknopf drücken und drehen. Wiederholter automatischer Impuls.



Art. CC.55

**E**

**Doppia Struttura: camera combustione separata da struttura esterna.**

Double Structure: combustion chamber separated by external structure.

Double structure : chambre de combustion séparée par une structure externe.

Doppelte Struktur: Brennkammer getrennt von der Außenstruktur.



Art. TOP FX.80T



Art. TOP FX.80T



Art. FDUAL.RIP



Art. FDUAL.RIP

<b>Art. 55T</b>	54 x 55 cm x H 18	53 x 40	20 kg	6-8	
<b>Art CA.55 / CC.55</b>	115 x 50 cm x H 77				

# MOMA 80T



**A**

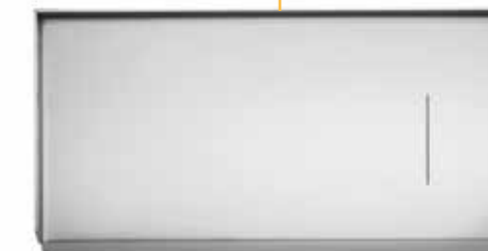

Art. 80T.L



Art. 80T.LR

**B**



Art. CC.80

<b>Art. 80T</b>	80 x 55 cm x H 18	79 x 40	28 kg	10-12	
<b>Art CA.80 / CC.80</b>	140 x 50 cm x H 77				









# CHEF

PLA.NET ORIGIN

Il prodotto storico di PLA.NET

**Rinnovato nel design del frontalino con integrato nuovo pulsante di accensione piezoelettronica (PEO/R). Migliorato nel retro con aletta diagonale che ne facilita il deflusso dell'aria calda e protegge la fiamma dall'entrata di aria esterna. Lineare nel suo stile ma altamente performante nella cottura, con camera di combustione separata che mantiene basse temperature esterne, per una migliore sicurezza.**

**Brucciatori a banda larga predisposti a modulo regolare per un riscaldamento uniforme di tutta la piastra.**



**EN** Renewed front panel design with integrated new piezoelectric starter button (PEO/R). Back side improved with a diagonal flap that facilitates the outflow of hot air and protects the flame from external air intake. Linear in style, yet highly performing in cooking, with a separate combustion chamber that maintains low external temperatures, for improved safety.

Broadband burners arranged with a regular module for uniform heating of the entire hot plate.

**FR** Rénové dans la conception du panneau frontal avec nouveau bouton d'alimentation piézoélectronique intégré (PEO / R). Amélioré à l'arrière avec un volet diagonal qui facilite la sortie de l'air chaud et protège la flamme de l'entrée d'air extérieur. Linéaire dans son style mais très performant en cuisine, avec une chambre de combustion séparée qui maintient des températures extérieures basses pour une meilleure sécurité. Brûleurs à large bande disposés avec un module régulier pour un chauffage uniforme de toute la plaque.

**DE** Erneuert im Design der Frontabdeckung mit neuem piezoelektrischem Einschaltknopf (PEO/R). Verbessert an der Rückseite mit diagonalem Flügel, der den Ablass der Warmluft erleichtert und die Flamme vor Eindringen der Außenluft schützt. Linearer Stil, aber hochleistungsfähig im Kochen, mit separater Brennkammer, welche die Außentemperaturen für bessere Sicherheit niedrig hält. Modular angeordnete breitbandige Brenner für gleichmäßiges Erhitzen der gesamten Platte.



				S.S. / INOX
55-80-80MIX	GAS	AA 1,5V	PEO/R	A 304L

# CHEF 55

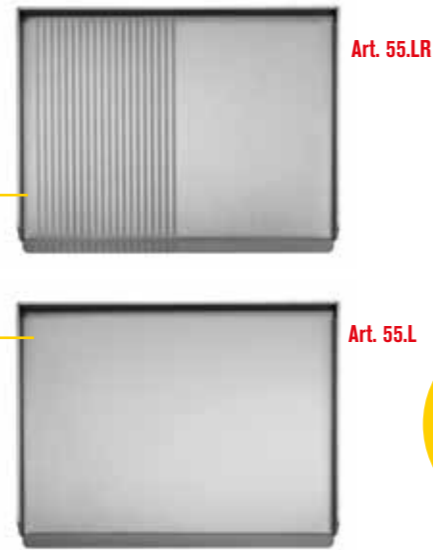

A

A

### Piastra Riscaldamento Uniforme: posizionamento equidistante dei bruciatori.

Uniform heating plate: equidistant positioning of the burners.

Plaque chauffante uniforme : positionnement équidistant des brûleurs.

Gleichmäßig erhitzte Platte: Brenner in gleichem Abstand positioniert.

C

### Doppia Struttura: camera combustione separata da struttura esterna.

Double Structure: combustion chamber separated by external structure.

Double structure : chambre de combustion séparée par une structure externe.

Doppelte Struktur: Brennkammer getrennt von der Außenstruktur.

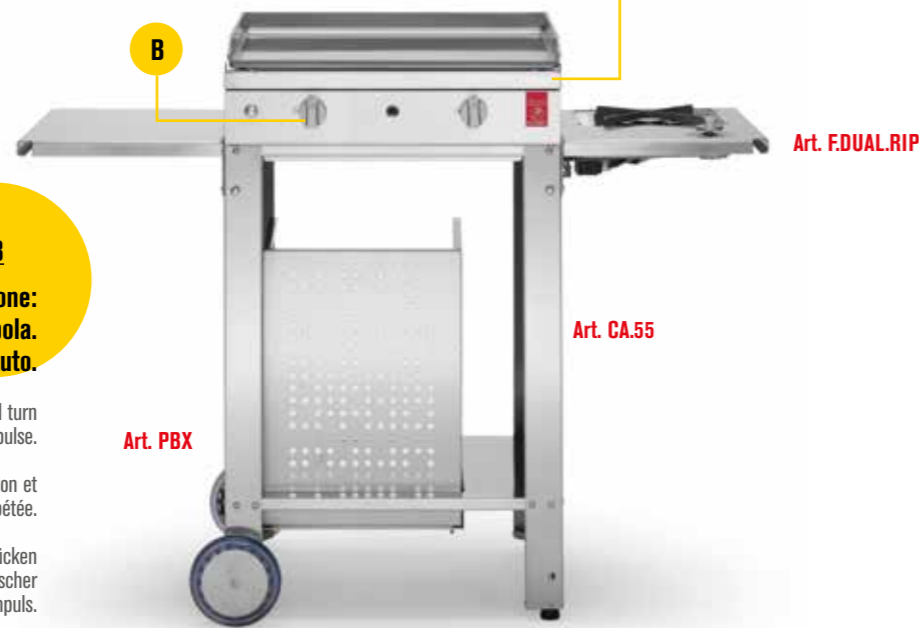

Art. PBX

Art. CA.55

Art. FDUAL.RIP

### Accensione Piezoelettronica a Ripetizione: premere il pulsante e girare la manopola. Impulso automatico ripetuto.

Repeating Piezoelectric Starter: press the button and turn the knob. Repeating automatic pulse.

Allumage piézoélectronique: appuyez sur le bouton et tournez la manette. Impulsion automatique répétée.

Wiederholte Piezoelektrische Zündung: die Taste drücken und den Drehknopf drehen. Wiederholter automatischer Impuls.

<b>Art. 55</b>	54 x 50 cm x H 20	53 x 40	20 kg	6-8
<b>Art CA.55 / CC.55</b>	115 x 50 cm x H 77			

# CHEF 80

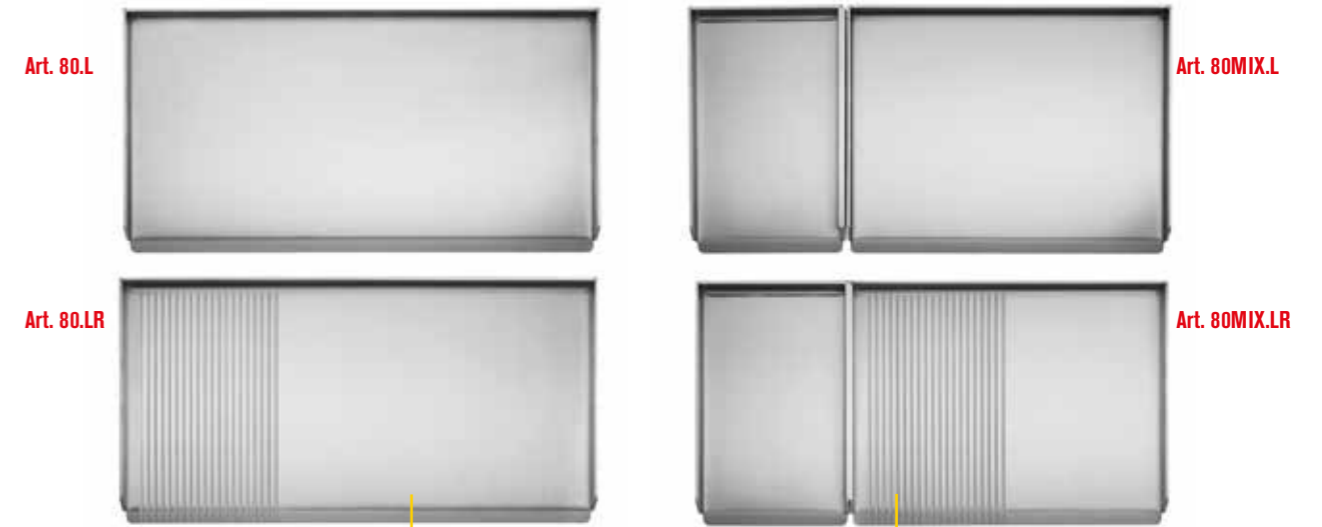

Art. 80.L

Art. 80MIX.L

Art. 80.LR

Art. 80MIX.LR



Art. TOP FX.55



Art. TOP FX.80



Art. CC.80

					⋮				
<b>Art. 80</b>	81 x 50 cm x H 20	79 x 40	30 kg	10-12	⋮	10-12	30 kg	26+53 x 40	<b>Art. 80MIX</b>
<b>Art. CA.80 / CC.80</b>	140 x 50 cm x H 77				⋮				<b>Art CA.80 / CC.80</b>
									81 x 50 cm x H 20
									140 x 50 cm x H 77



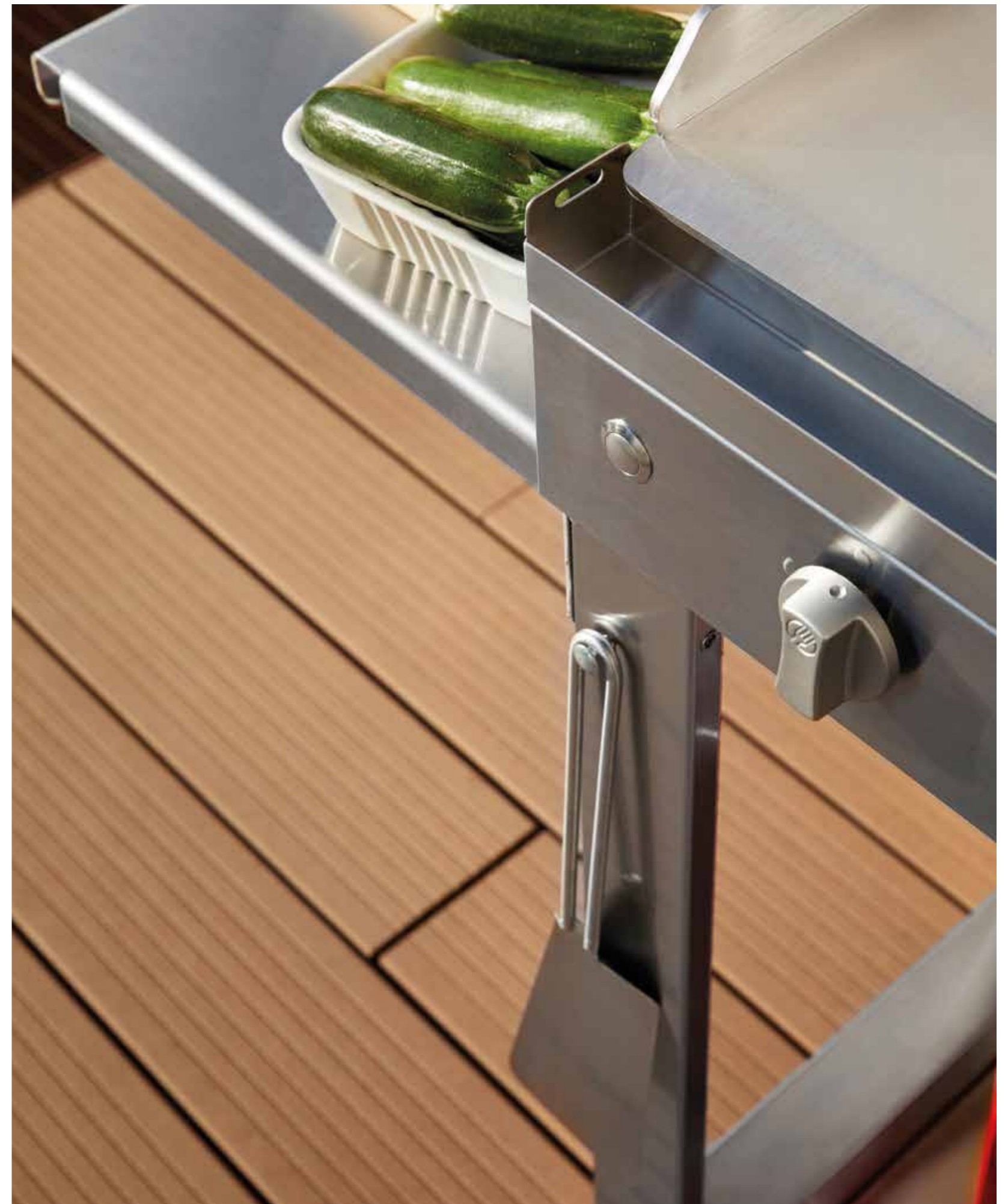



# ALFA

BASIC - FUNCTION

Essenziale e funzionale



Art. GLA600.XL

**Inalterate le caratteristiche funzionali del piano cottura PLA.NET (doppia struttura di sicurezza, piastra rinforzata e amovibile, bacinella raccogligrassi, piedini regolabili) in un design essenziale.**

**Bruciatori a banda larga predisposti a modulo regolare per uniforme riscaldamento di tutta la piastra.**

**Accensione Piezoelettrica Integrata (PE/I), premere e girare la manopola, impulso singolo integrato, per il modello A600. Accensione Piezoelettrica a Pulsante (PE/P) premere e girare la manopola e insieme premere il pulsante (impulso singolo), per il modello 40A.**

**EN\_** The PLA.NET hob functional features have remained unaltered (double safety structure, reinforced and removable plate, drip tray, adjustable feet) in an essential design. Broadband burners arranged with a regular module for uniform heating of the entire hot plate. Integrated Piezoelectric Starter (PE/I), press and turn the knob, integrated single pulse, for model A600. Push-button Piezoelectric Starter (PE/P) press and turn the knob then press the button (single pulse), for model 40A.

**FR\_** Il arbore les mêmes caractéristiques fonctionnelles du plan de cuisson PLA.NET (double structure de sécurité, plaque renforcée et plateau amovible, bassin collecte graisses, pieds réglables) dans un design essentiel. Brûleurs à large bande préparés avec un module régulier pour un chauffage uniforme de toute la plaque. Allumage piézoélectrique intégré (PE / I), appuyez sur le bouton rotatif à impulsion unique intégré pour le modèle A600. Allumage piézo-électrique à bouton-poussoir (PE / P). Appuyez sur le bouton et tournez-le, puis appuyez simultanément sur le bouton (à impulsion unique) pour le modèle 40A.

**DE\_** Unverändert bleiben die Betriebseigenschaften der Kochplatte PLA.NET (doppelte Sicherheitsstruktur, verstärkte und abnehmbare Platte, Fettsammelwanne, verstellbare Füße) mit essenziellem Design. Modular angeordnete breitbandige Brenner für gleichmäßiges Erhitzen der gesamten Platte. Integrierte Piezoelektrische Zündung (PE/I), den Drehknopf drücken und drehen, integrierter Einzelimpuls, für das Modell A600. Piezoelektrische Zündung mit Taste (PE/P), den Drehknopf drücken und drehen und gleichzeitig die Taste drücken (Einzelimpuls), für das Modell 40A.



Art. GL40A.XL



Art. COP.60



Art. PAR.60

<b>Art. GLA600.XL</b>	37 x 50 cm x H 20	37 x 40	11 kg	4-6
<b>Art. GL40A.XL</b>	60 x 50 cm x H 20	60 x 40	19 kg	6-8

				S.S. / INOX
<b>A600 - 40A</b>	GAS	AA 1,5V	PE/I - PE/P	A.430





# ACCIAIO INOX (AISI-ACCIAIO INOSSIDABILE)

Diverse le tipologie in commercio, sotto la denominazione di acciaio AISI (American Iron and Steel Institute). E una lega caratterizzata dall'alta resistenza all'ossidazione e corrosione grazie alla presenza di Cromo e Nichel in varie percentuali. Molti i campi di impiego e le sigle (leghe) che li identificano (settore: alimentare, casalingo, arredamento, navale e costruzioni).

## PLA.NET UTILIZZA DA SEMPRE TRE TIPOLOGIE DI ACCIAIO INOX:

### INOX A.430:

buona resistenza all'ossidazione e massima conducibilità del calore. Il più utilizzato nel settore alimentare e casalingo.

### INOX A.304L:

(18/10) ottima resistenza all'ossidazione e ottima conducibilità del calore. Il materiale principe nel settore della ristorazione professionale.

### INOX A.316:

massima resistenza all'ossidazione e buona conducibilità del calore. Indicato anche come marino, per il suo impiego nel settore navale e chimico.

## MANUTENZIONE ACCIAIO INOX:

I prodotti PLA.NET possono essere lasciati all'aperto.

Si consiglia tuttavia qualche precauzione necessaria ad un migliore mantenimento del prodotto dato che anche l'acciaio inox, come tutti i materiali, ha bisogno di cura e manutenzione, che varia in base alle sue caratteristiche (tipologie acciaio) e all'ambiente in cui si trova, più o meno aggredibile dalle condizioni ambientali e atmosferiche. La sua bellezza e durata dipende solo da questo. Per maggiori informazioni: vedi il sito PLA.NET alla voce istruzioni.

## STAINLESS STEEL (AISI)

AISI (American Iron and Steel Institute) characterizes different type of SS all over marketplace, this particular kind of alloy is marked by high resistance to oxidation and corrosion, thanks to chromium and nickel's settlement in various proportion. This type of Stainless Steel (used for example for food, home, furnishing, shipbuilding and buildings) has different field application and it is identified by different acronyms.

## PLA.NET has always used 3 types of Stainless Steel:

**A.430:** good oxidation resistance and maximum heat conductivity. The most used Stainless Steel in food and home industry.

**A.304L:** (18/10) excellent oxidation resistance and excellent heat conductivity. The main material in the professional cooking sector.

**A.316:** excellent oxidation resistance and good heat conductivity. Named also as "marine steel", about its use in the naval and chemical industries.

## STAINLESS STEEL MAINTENANCE

Our products can be left outdoors. However, we recommend some precautions, necessary for a better maintenance of the product. Stainless Steel, like every materials, needs care and maintenance, different for the type of material and environment in which it's located (more or less vulnerable to environmental and atmospheric conditions). Beauty and durability of every materials depends only on this. For more information: see the PLA.NET website under instructions.





# WATT

GREEN ENERGY

Strutture in acciaio inox  
e piani cottura in inox o vetroceramico

**La cottura diventa più green con l'utilizzo di resistenze elettriche schermate per riscaldare il piano cottura, con possibilità di scegliere tra acciaio inox e piano in vetroceramica. Grande velocità di riscaldamento e massima uniformità di calore, garantita da un corpo riscaldante uniforme su tutta la superficie di cottura. Protetto nella parte inferiore da materiale isolante per minimizzare la dispersione di calore verso il basso, massimizzando l'apporto di calore alla piastra.**

**EN\_** Cooking becomes 'greener' through the use of shielded electric heaters for heating the hob; you can choose either the stainless steel or the glass ceramic hob. High heating speed and maximum homogeneity of heat, guaranteed by a uniform heating body over the entire cooking surface. Protected in the lower part by insulating material to minimize heat dispersion downwards, thus maximizing the supply of heat to the plate.

**FR\_** La cuisson devient plus verte grâce à l'utilisation de radiateurs électriques blindés pour chauffer la table de cuisson, avec la possibilité de choisir entre un plan de cuisson en acier inoxydable et en vitrocéramique. Vitesse de chauffage élevée et uniformité maximale de la chaleur, garanties par un corps chauffant uniforme sur toute la surface de cuisson. Protégé dans la partie inférieure par un matériau isolant pour minimiser la dispersion de la chaleur vers le bas, maximisant ainsi l'apport de chaleur vers la plaque.

**DE\_** Das Kochen wird grüner durch die Verwendung von abgeschirmten elektrischen Widerständen zur Erwärmung des Kochfeldes, mit der Möglichkeit der Wahl zwischen Edelstahl und einer Kochplatte aus Glaskeramik. Sehr schnelles Aufheizen und maximale Gleichmäßigkeit der Wärme wird von einem Heizelement gewährleistet, das auf der gesamten Kochfläche einheitlich arbeitet. Durch Isoliermaterial am unteren Teil geschützt, um den Wärmeverlust nach unten hin auf ein Minimum zu reduzieren und so die Wärmezufuhr zur Platte zu optimieren.



	⚡	S.S. / INOX	kW	V
<b>EL 60</b>	EL	A 304L	24	230
<b>EL.PRO</b>	EL	A 304L + CERAMIC	25	230
<b>EL.SLIM</b>	EL	A 304L + CERAMIC	23	230



## WATT EL60

**Front Control Panel: comando frontale per accensione e regolazione temperatura.**

Front Control Panel: front control for lighting and temperature regulation.

Panneau de commande avant: commande avant pour la régulation de l'allumage et de la température.

Front Control Panel: frontale Bedienungselemente für Einschalten und Regeln der Temperatur.



**Piastra Riscaldamento Uniforme: resistenze riscaldanti a copertura totale.**

Uniform heating plate: total coverage heating elements.

Plaque chauffante uniforme: éléments chauffants à couverture totale.

Gleichmäßig erhitze Platte: Heizwiderstände mit Gesamtwärmeabdeckung.

## WATT EL PRO



**Blocco Resistenze Protette: blocco unico isolato tra piano cottura/ sistema resistenze.**

Protected Resistance Block: single block isolated between the hob/resistance system.

Bloc de résistances protégé: bloc unique isolé entre le système de cuisson / résistance.

Block geschützter Widerstände: isolierter einzelner Block zwischen Kochfeld/Widerstandssystem.

## WATT EL SLIM



**Doppia Struttura: blocco riscaldante separata da struttura esterna.**

Double Structure: heating block separated by external structure.

Double structure: bloc chauffant séparé par une structure externe.

Doppelte Struktur: Heizeinheit getrennt von der Außenstruktur.

						<b>kW</b>	<b>V</b>
<b>Art. EL 60</b>	60 x 51 cm x H 18	60 X 40	26 Kg	8	IPX4	24	230
<b>Art. EL PRO</b>	50 x 45 cm x H 10	49 X 34	13 Kg	4-5	-	25	230
<b>Art. EL SLIM</b>	52(+10) x 32 cm x H 7	49 X 32	7 Kg	4-5	-	23	230





# OASI

YOUR OUTDOOR COOKING STATION

la cucina esce all'esterno



**Modulare, componibile e nomade, con più soluzioni: cottura gas o elettrico, postazione di lavoro e lavaggio. Piani cottura inox, gas o elettrici, piano fornelli gas o in vitroceramica a induzione. Lavello con rubinetto abbattibile e comodi piani di appoggio/lavoro. Il tutto posizionabile in cooking station aperte o chiuse oppure su progetto del cliente in una struttura personalizzata nei materiali e nel design.**

**EN** Modular, sectional and nomadic, with various solutions: gas or electric cooking, workstation and washing section. Stainless steel, gas or electric hobs, gas hob or ceramic-glass induction hob. Sink with collapsible tap and comfortable work /support surfaces. Can be positioned in open or closed cooking stations or based on a customer's project with tailor-made materials and design.

**FR** Modulaire, personnalisable et nomade, avec plus de solutions : cuisson au gaz ou électrique, poste de travail et lavage. Plans de cuisson en acier inoxydable, à gaz ou électriques, plan de fourneaux à gaz ou en vitrocéramique à induction. Évier avec robinet pliable et confortable des surfaces de support / travail. Vous pouvez agencer le tout dans des postes de cuisson ouverts ou fermés ou d'après le projet d'un client dans une structure personnalisée en matériaux et en conception.

**DE** Modular, zusammensetzbar und mobil, mit mehreren Lösungen: Kochen mit Gas oder elektrisch, Arbeits- und Waschstand. Kochflächen in Edelstahl, mit Gas oder elektrisch, Gasherdflecken oder aus Glaskeramik mit Induktion. Waschbecken mit klappbarem Wasserhahn und bequemen Ablage- bzw. Arbeitsflächen. Das Ganze kann in offenen oder geschlossenen Kochstationen, oder nach Zeichnung des Kunden in einer Struktur mit kundenspezifischen Materialien und Design zu positioniert werden.



## OASI 97 COMBINATIONS



1



2



4



3

## OASI 142-142C COMBINATIONS



5



6

## OASI 183-183C COMBINATIONS



7



9



8



10

COMBINATIONS	N	ARTICLES	OASI	↔	⚖️
	1	OASI 97 + IN.55COMBI.LR + IN.FLAP (x 2) + PBX	97	97 x 56 H 88 cm	30
2	OASI 97 + IN.INDU + IN.FLAP (x2)	142	142 x 56 H 88 cm	40	
3	OASI 97 + IN.LAV34 + SOTTO + IN.FLAP (x2) + PBX	142.C	142 x 56 H 88 cm	52	
4	OASI 97 + IN.EL60.XL + IN.FLAP (x2)	183	183 x 56 H 88 cm	45	
5	OASI 142.C + IN.55COMBI.LR	183.C	183 x 56 H 88 cm	55	
6	OASI 142.C + IN.EL60.XL	205	205 x 56 H 88 cm	48	
7	OASI 183 + IN.INDU + IN.EL60.XL	205.C	205 x 56 H 88 cm	60	
8	OASI 183 + IN.LAV.34 + SOTTO + IN.55COMBI.LR + PBX				
9	OASI 183 + IN.LAV.34 + SOTTO + IN.EL60.XL				
10	OASI 183 + IN.LAV.34 + SOTTO + IN.55COMBI.LR				



# COMBINATIONS / OASI 205

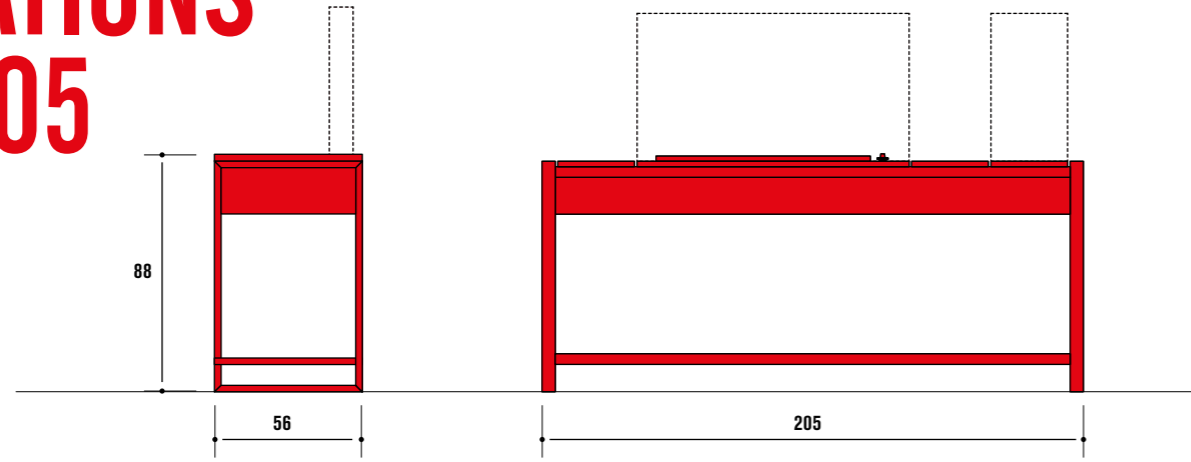

board + IN 80.L + board + IN FR

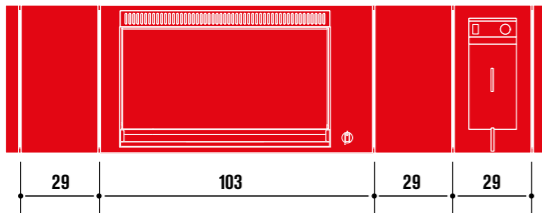

board + IN 80.L + board + IN F.Dual

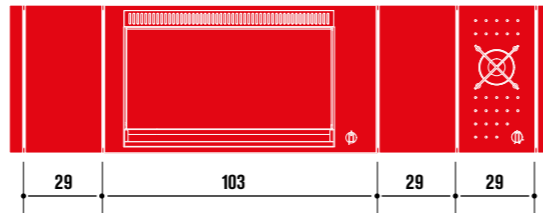

board + IN 80.L + IN LAV

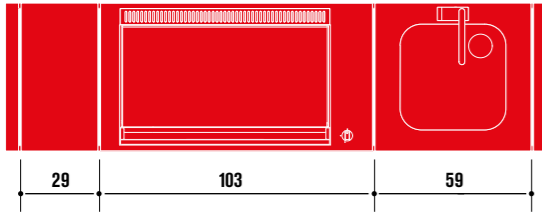

IN 80MIX.LR + IN F.Dual + IN LAV

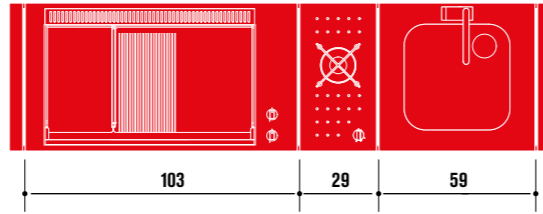

board + IN 55.LR + board + IN F.Dual + IN FR

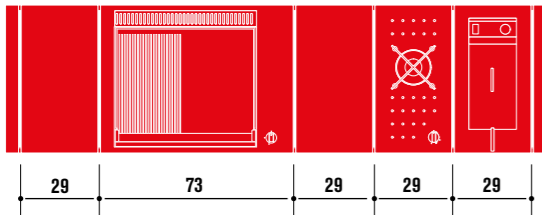

board + IN 55.L + IN F.Dual + IN LAV

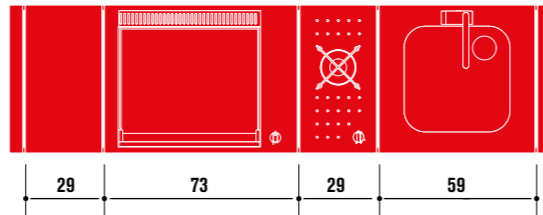

board + IN 55.LR + board + IN F3

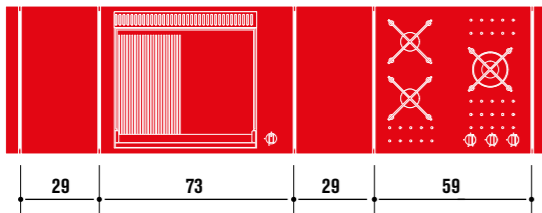

board + IN 55.L + IN FR + IN LAV

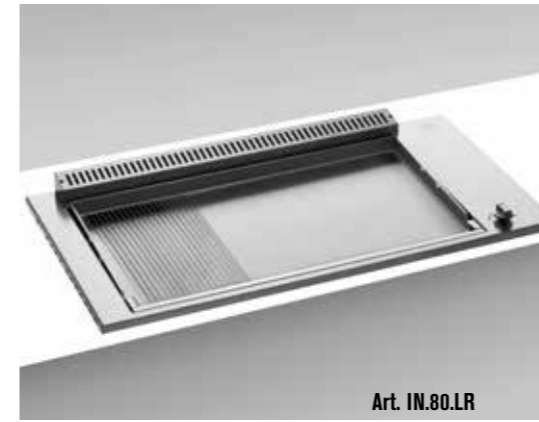
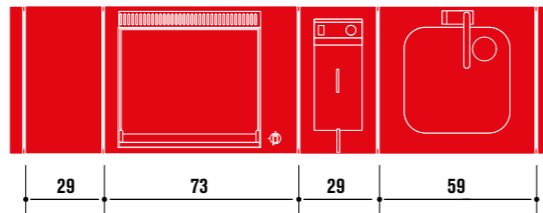

Art. IN.80.LR  
(Art. IN.80.L)

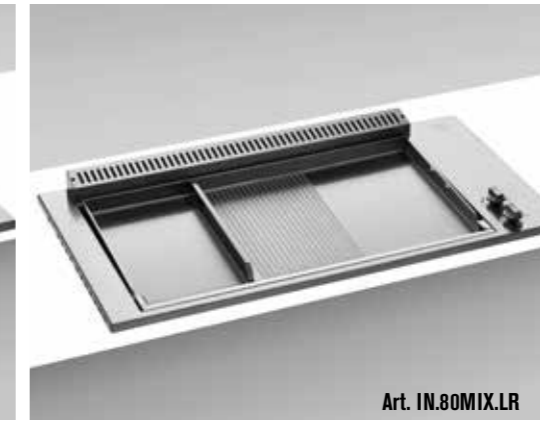

Art. IN.80MIX.LR  
(Art. IN.80MIX.L)



Art. IN.55.L  
(Art. IN.55.LR)

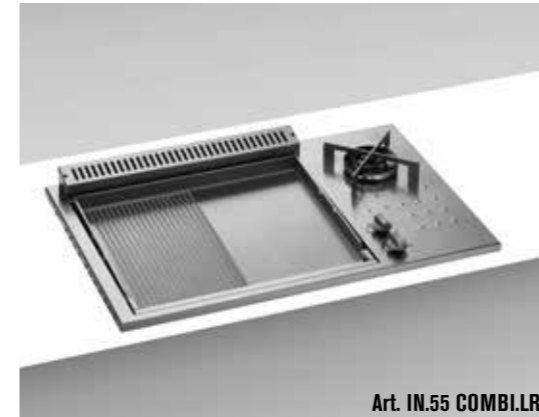

Art. IN.55 COMBI.LR  
(Art. IN.55 COMBI.L)

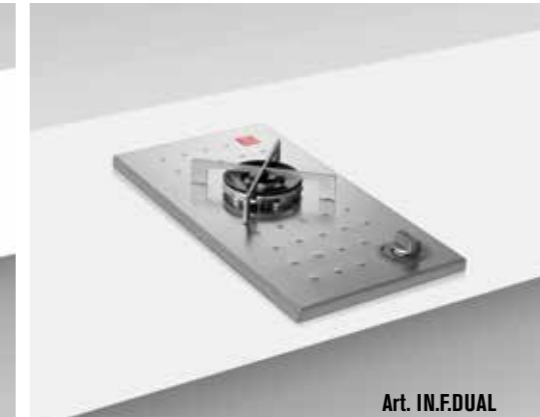

Art. IN.FDUAL

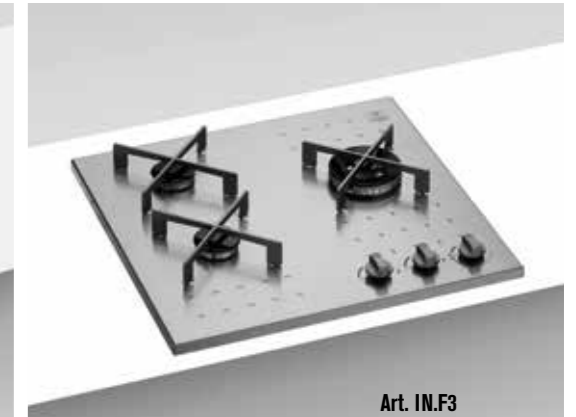

Art. IN.F3



Art. IN.LAV34+SOTTO

**INCASSO DEI  
COMPONENTI  
OASI / BUILT IN**

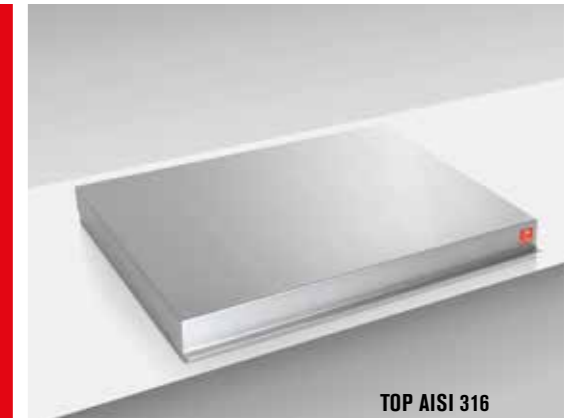

TOP AISI 316  
(INCLUDED)



Art. IN.FR

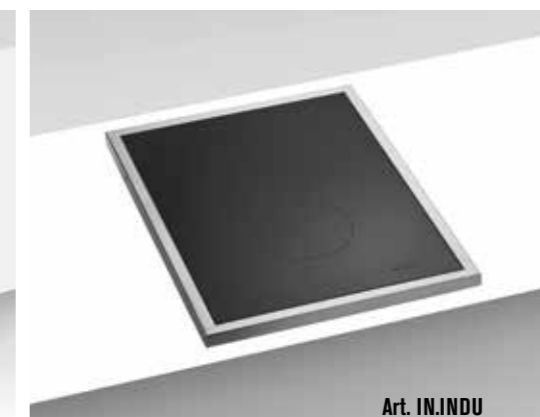

Art. IN.INDU



Art. IN.EL60.XL







# LA TUA OUTDOOR COOKING PLANET:

una zona di cottura completa e funzionale con  
lavandino per ripulire dopo la cottura.

Ampia scelta di misure e composizioni  
personalizzabili secondo le esigenze del cliente.

EN>Your outdoor cooking planet: a complete and functional cooking area including a sink to clean up after cooking.  
A wide selection of customizable sizes and compositions according to customer needs.

FR\_Votre planète de cuisson en pleine air : une zone de cuisson complète et fonctionnelle avec évier pour nettoyer après la cuisson. Large choix de mesures et de compositions personnalisable selon les besoins du client.

DE\_Ihr Outdoor Cooking Planet: ein kompletter und funktionaler Kochbereich mit Waschbecken zum Reinigen nach dem Kochen. Große Auswahl an Maßen und Konfigurationen, die je nach Bedürfnis kundenspezifisch angepasst werden können.



PRIVATE HOUSE - Israel



PRIVATE HOUSE - Italy



PRIVATE HOUSE - Italy



CASA 1N - Croatia



INSIDE CREATION - France



BENTLEYCUCINE - Austria



©FABRICE GAL



# INSTALLAZIONE / INSTALLATION

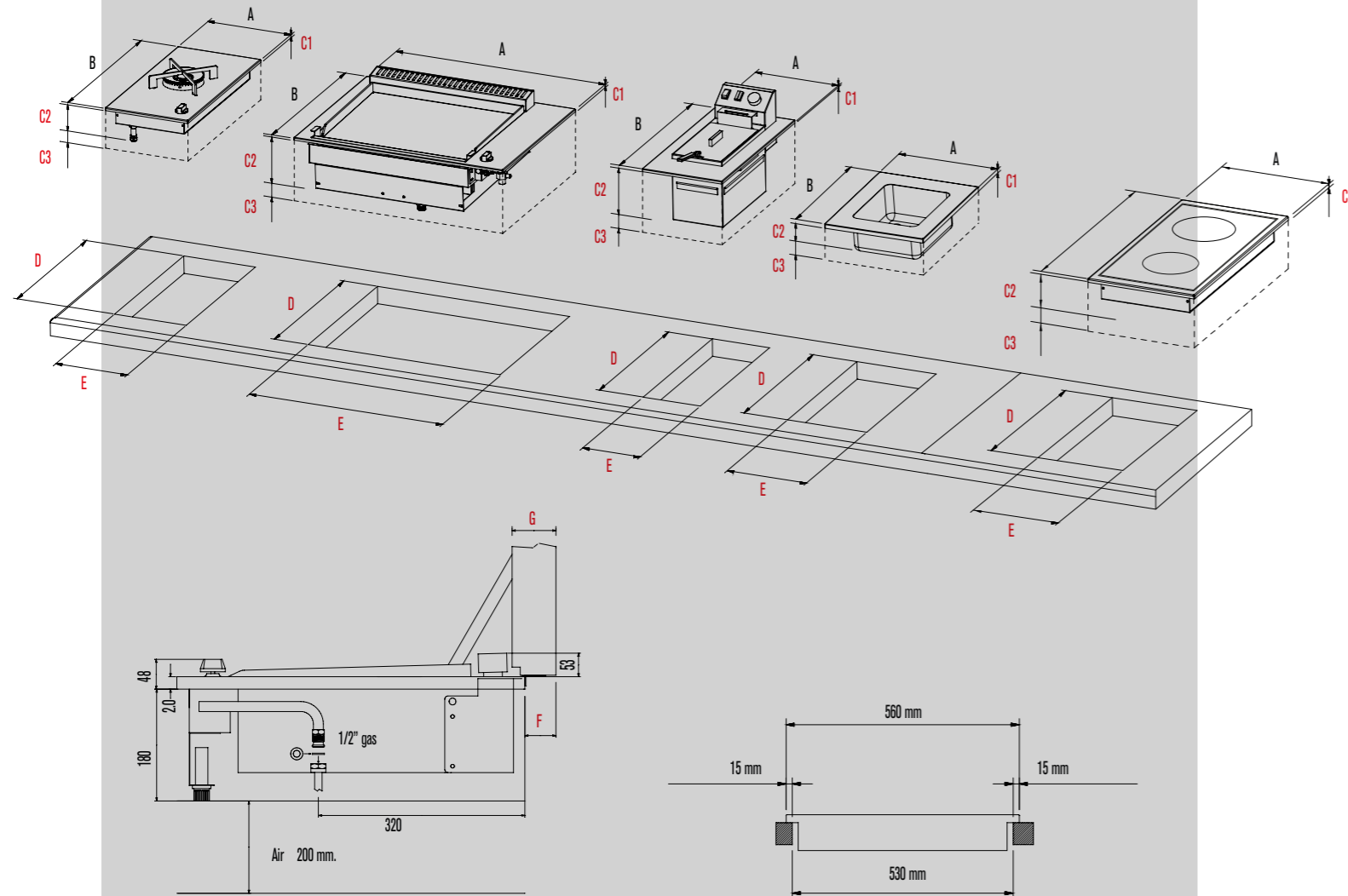

					S.S. / INOX		kW	V
<b>IN.55 -55COMBI</b>	GAS	AA 1,5V	PE0/I	P.G.S.	A 304L-316	6-8	-	-
<b>IN.80-80MIX-80COMBI</b>	GAS	AA 1,5V	PE0/I	P.G.S.	A 304L-316	10-12	-	-
<b>IN.EL60</b>	-	AA 1,5V	EL	IPX4	A 304L-316	8-10	24	230

## L'INSTALLAZIONE È MOLTO SEMPLICE.

Basta predisporre un foro sul piano d'appoggio e inserirci il piano cottura, che potrà essere fissato al piano utilizzando le apposite staffe a "L" regolabili, con perno filettato da avvitare al piano di appoggio. Collegare quindi l'entrata del gas alla bombola se predisposto per GPL (butano/propano) o alla rete se predisposto a metano. **Attenzione: per il buon funzionamento dei prodotti (barbecue in particolare), le manutenzioni e per la vostra sicurezza, è indispensabile seguire alcune avvertenze in merito a: materiali supporto, posizionamenti e distanze, aerazioni. Avvertenze disponibili su richiesta e presenti nel manuale istruzioni.**

Dimensioni mm	IN.55	IN.80 80mix	Combi 55+Fdual	Combi 80+Fdual	IN.FDual	IN.F3	IN.EL60	IN.FR	IN.INDU	IN.LAV	IN.LAV34
<b>A</b>	730	1030	850	1150	290	590	850	290	318	590	400
<b>B</b>	560	560	560	560	560	560	560	560	560	560	560
<b>C1</b>	20	20	20	20	20	20	20	20	20	20	20
<b>C2</b>	180	180	180	180	90	80	140	190	52	200	200
<b>C3</b>	200	200	200	200	150	150	150	50	150	150	150
<b>C2+C3</b>	380	380	380	380	240	230	290	240	202	350	350
<b>D</b>	530	530	530	530	530	530	530	530	475	530	530
<b>E</b>	700	1000	820	1120	260	560	820	260	270	560	370
<b>F</b>	70	70	70	70	70	70	70	120	70	-	70
<b>G</b>	90	90	90	90	90	90	90	131	90	-	90

**EN** It's very simple. It's enough to set a hole on the support board and insert the hob which can be fixed by means of designated L-shaped adjustable brackets, with a threaded pin to be screwed to the supporting top. Connect the inlet of gas to the bottle if set for LPG (butane-propane) or to the main supply if set for methane. Attention: for the correct operation (of the barbecue in particular), for the maintenance and for your safety, it is necessary to follow a few warnings/rules concerning: support materials, placement and distances, ventilation. Warnings available on request and specified in the instruction manual.

**FR** Extrêmement simple. Il suffit de réaliser une découpe sur le plan de travail et d'insérer le plan de cuisson, qui pourra être vissé dessus avec l'étrier réglable en L à tige filetée. Puis raccorder l'entrée du gaz à la bouteille pour le GPL (butane/propane) ou à votre installation au gaz de ville (méthane) selon votre souhait. Attention: pour le correct fonctionnement des produits (en particulier du barbecue), la maintenance et pour votre sécurité, il faut suivre quelques précautions concernant: matériel support, placement et distances, aération. Précautions disponibles sur requête et notées dans le manuel d'instructions.

**DE** Sehr einfach. Sie müssen nur eine Öffnung auf der Auflagefläche ausschneiden und die Grillplatte einlassen; diese kann mit Hilfe der entsprechend einstellbaren "L"-förmigen Bügel an der Platte befestigt und mit dem Gewindestift an die Auflagefläche angeschraubt werden. Anschließend müssen Sie den Gaseingang an die Gasflasche (bei Flüssiggas Butan/Propan) bzw. an die Erdgasleitung anschließen. Achtung für eine einwandfreie Funktion der Produkte (insbesondere Barbecue-Grills), eine leichte Wartung und zu Ihrer Sicherheit müssen Sie die Hinweise zu Stützmaterialien, Positionierungen und Entfernungen sowie zur Lüftung beachten. Die Hinweise werden auf Anfrage mitgeteilt und sind auch in der Bedienungsanleitung aufgeführt.

# ACCESSORI / ACCESSORIES

- **RACCOGLITORE LATERALE 2LT**  
2- lt side basin
- **PARASPRUZZI**  
Splash guards
- **COPERCHIO TOP**  
Top lids



Art. TANK.55T  
Art. TANK.80T  
Art. TANK.55  
Art. TANK.80

- Art. PAR.55
- Art. PAR.80
- Art. PAR.80MIX
- Art. PAR.60
- Art. PAR.EL.PRO
- Art. PAR.EL.SLIM



Art. COPEL.SLIM



- **COPERCHIO TOP**  
Top lids
- **COPERCHIO TOP**  
Top lids
- **COPERCHIO TOP**  
Top lids



Art. COP.60

Art. COPEL.60



Art. COPEL.PRO



- **COPERCHIO TOP**  
Top lids
- **COPERCHIO TOP**  
Top lids
- **CARRELLO APERTO MULTIUSO**  
Multipurpose open trolley



Art. TOP FX.55  
Art. TOP FX.80

Art. TOP FX.55T  
Art. TOP FX.80T



Art. CA.SMART



- **FORNELLO APPOGGIO**  
Double crown cooker
- **FORNELLO SU RIPIANO**  
Double crown cooker on shelf
- **FORNELLO SU RIPIANO**  
Double crown cooker on shelf



Art. EDUAL

Art. EDUAL.RIP



Art. EDUAL.RIP



- **FRIGGITRICE APPOGGIO**  
Countertop fryer and on shelf
- **FRIGGITRICE SU RIPIANO**  
Countertop fryer and on shelf
- **PLANCHA PER BBQ**  
Plancha for bbq



Art. FR

Art. FR.RIP



Art. P@G



- **PLANCHA PER BBQ**  
Plancha for bbq
- **GRILL ELLETTRICO**  
Electric Gril
- **GRILL ELLETTRICO**  
Electric Gril



Art. P@G

Art. V.GRILL



Art. V.GRILL





- **PLANCHA PER BBQ**  
Plancha for bbq
- **COPRI BOMBOLA**  
Cylinder Cover
- **CONTENITORE OASI STATION**  
Oasi station shelf with compartment

Art. P@G 6040  
Art. P@G 4834  
Art. P@G 3040



Art. PBX



Art. IN.VAN.40



- **LAMPADA LED**  
Led Lamp
- **PORTA ROTOLO**  
Paper holder
- **COPERCHIO PIANO COTTURA**  
Cooking lid

Art. IN.LAMP



Art. IN.PAPER



Art. BOWL

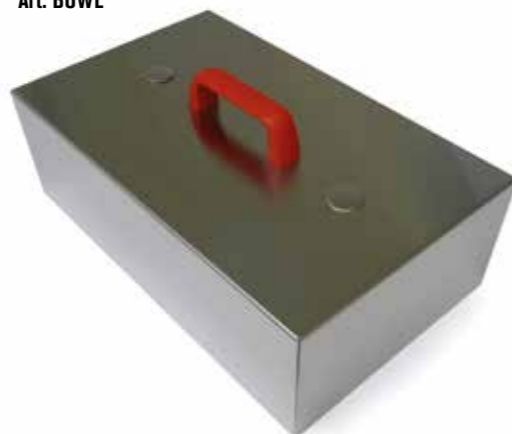

- **RIPIANO LATERALE OASI STATION**  
Oasi station opening shelf
- **TAGLIERE**  
Cutting board
- **ANTA APRIBILE DA INCASSO**  
Built-in door with frame

Art. IN.FLAP



Art. IN.CUT



Art. IN.DOOR 55  
Art. IN.DOOR 80

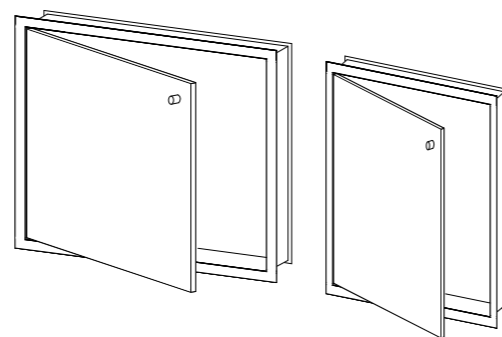

- **ACCESSORI PULIZIA**  
Cleaning accessories
- **ACCESSORI PULIZIA**  
Cleaning accessories
- **ACCESSORI PULIZIA**  
Cleaning accessories

Art. CLEAN.INOX500  
(in n.6 pezzi)



Art. CONF.RALL  
Art. CONF.LL



Art. C.P.MAXI



- **ACCESSORI PULIZIA**  
Cleaning accessories
- **ACCESSORI PULIZIA**  
Cleaning accessories
- **TOTEM**  
Totem

Art. CLEAN.PLANET500  
(in n.6 pezzi)



Art. CONF.PABR



TOTEM



- **COVER**  
Protective Canvas
- **COVER**  
Protective Canvas
- **SET ATTREZZI COTTURA**  
Cooking tools

Art. TELO.BBQ55  
Art. TELO.BBQ80  
Art. TELO.BBQ60



Art. TELO.115  
Art. TELO.141



Art. KIT.4.ACC  
Art. A.PAL  
Art. A.PIN  
Art. A.COL  
Art. A.FOR





# AZIENDA / COMPANY

**Società fondata nel 1988 da operatori esperti nella lavorazione dell'acciaio inox nel settore della ristorazione professionale.**

**Situata nel nord-est d'Italia, nel distretto di Conegliano (Treviso), specializzato nella produzione di elettrodomestici e impianti per la ristorazione professionale. Si sviluppa in due unità produttive per 5.000mq coperti. Da questo know how, nel 2005 nasce il progetto a marchio PLA.NET, che propone la cottura su piastra acciaio inox, all'esterno, destinata alla famiglia, quale evoluzione del sistema tradizionale barbecue. Una sintesi delle esperienze internazionali di cottura su piastra.**

.....

The company was founded in 1988 by experts in stainless steel processing in the professional catering sector. It is located in the north-east of Italy, in the district of Conegliano (Treviso) and is specialized in the production of home appliances and systems for professional catering. It is made up of two production units covering 5,000 sq m. As a result of this know-how, the PLA.NET brand project was launched in 2005; a brand that offers stainless steel plate cookers, external use, for the family, as an evolution of the traditional barbecue system. A combination of international cooking experiences on a single hot plate.



## UNIT 1:

Dedicata alla lavorazione di laminati piani come acciaio, acciaio inox, bimetallo (acciaio+acciaio inox) trimetallo (inox+alluminio+inox), con spessori da 5 a 40mm.

Ciclo lavorazione completo: taglio, fresatura, tornitura, satinatura, lucidatura, saldatura robotizzata, pallinatura, pulitura. Realizzazione di piani cottura destinati al settore della ristorazione e cottura domestica. Per un totale di 2400 mq.

.....

Area dedicated to processing flat laminates such as steel, stainless steel, bimetal (steel + stainless steel) trimetal (stainless + aluminium + stainless steel), with thickness ranging from 5 to 40 mm.

Complete processing cycle: cutting, milling, turning, satin finishing, polishing, robotic welding, shot blasting, cleaning. We manufacture hobs for the catering and domestic cooking sector. For a total of 2,400 sq m.

## UNIT 2:

Dedicata alla lavorazione dell'acciaio inox con spessori da 0,8 a 3mm. Ciclo lavorazione completo: taglio, punzonatura, piegatura, satinatura, saldatura robot, pallinatura, pulitura, assemblaggio. Si realizzano componenti in acciaio inox per il settore della ristorazione professionale che per la cottura domestica come: fry top, teppanyaki, piastre di cottura x barbecue, carrelli, tavoli. Superficie occupata 2.600 mq

.....

Area dedicated to processing stainless steel with thicknesses ranging from 0.8 to 3 mm. Complete processing cycle: cutting, punching, bending, satin finishing, robot welding, shot blasting, cleaning, and assembly. We manufacture stainless steel components, for both the professional catering sector and the domestic cooking sector, such as: fry tops, teppanyaki, cooking plates for barbecues, trolleys, tables. Area occupied - 2,600 sq m

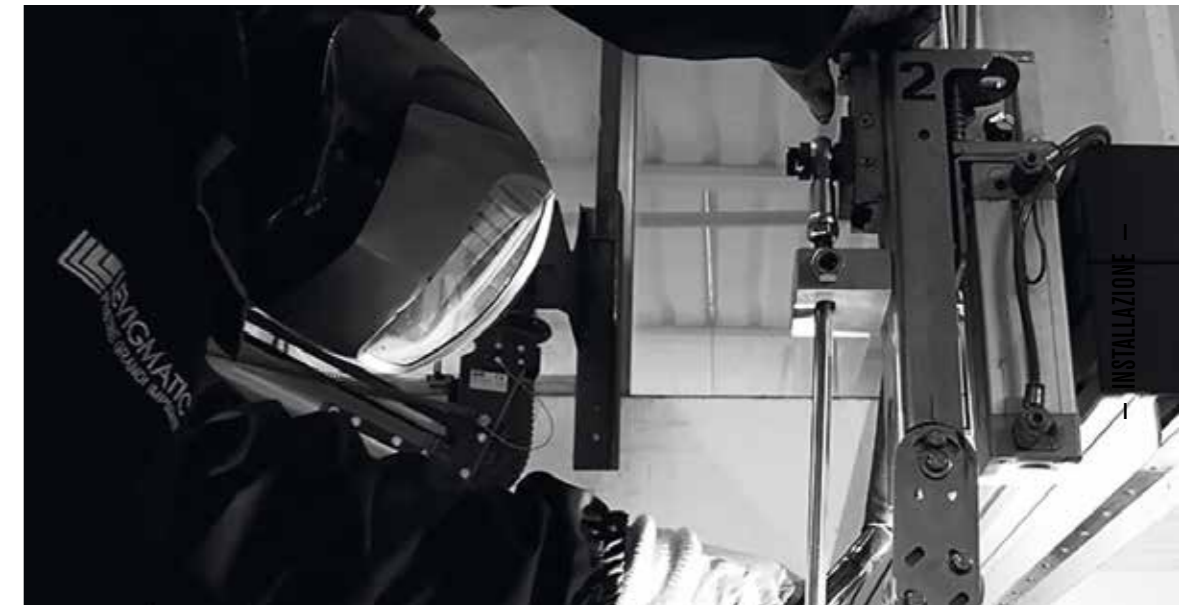



**Levigmatic S.r.l.**  
**Presenti nei 5 continenti in 20 paesi**

**EUROPA**

Belgio  
Croazia  
Francia  
Germania  
Gran Bretagna  
Grecia  
Italia  
Olanda  
Polonia  
Rep. Ceca  
Slovenia  
Spagna  
Svizzera

**AFRICA**

Algeria

**AMERICA**

Brasile  
Canada

**ASIA**

Indonesia  
Giordania

**OCEANIA**

Australia  
Nuova Zelanda

**CREDITS:**

Art direction Pla.net: Marco De luca

Graphic Design: Mirco Luzzi

Photo: Studio Rocci

**Thanks to:**

Fabrizio Nonis BEKÉR – On Tour

Berto's S.p.a.

Levigmatic Srl si riserva di apportare ai propri prodotti qualsiasi modifica ritenuta utile al miglioramento qualitativo degli stessi, sia dimensionale che strutturale. Foto, disegni e testi non hanno carattere contrattuale.

*Levigmatic Srl reserves the right to make any modifications to its products that it feels may improve their appearance or quality, either dimensional or structural. Photos, drawings and texts are not contractually binding.*

Tutti i diritti riservati. E' vietata la riproduzione anche parziale delle immagini e testi.  
*All rights reserved. The reproduction of image, drawings and texts ,even if partial, is forbidden.*

**Production unit 1**

**LEVIGMATIC Professional Cooking**

**Via dell'Industria, 71**

**31020 San Vendemiano (TV)**

**Tel: +39 0438 778161**

**Fax: +39 0438 778385**

**[www.levigmatic.it](http://www.levigmatic.it)**

**Production unit 2**

**PLA.NET Outdoor Cooking**

**Via dell'Industria, 39**

**31020 San Vendemiano (TV)**

**Tel: +39 0438 470552**

**Fax: +39 0438 478705**

**[info@planetbarbecue.it](mailto:info@planetbarbecue.it)**

**[www.planetbarbecue.it](http://www.planetbarbecue.it)**



**products strictly made in Italy**