

# AVENTOS HS

[www.blum.com](http://www.blum.com)

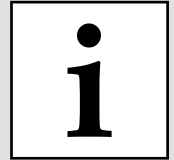



Standardanwendungen | Standard applications | Applications standard |  
 Applicazioni standard | Aplicaciones estándar | Rozwiązania standardowe

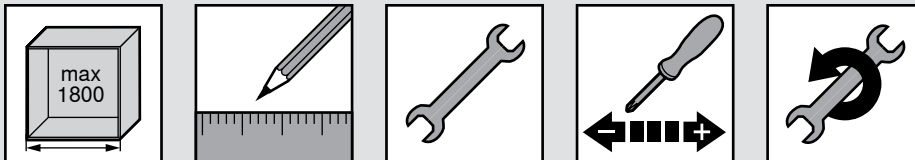

Sonderanwendungen | Special applications | Applications spéciales | Applicazioni speciali |  
 Aplicaciones especiales | Rozwiązania specjalne



> <http://www.blum.com/1fALex>

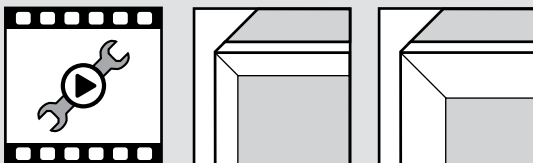

Planung | Planning | Planification |  
 Progettazione | Planificación | Planowanie

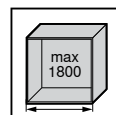

Korpusbreite | Cabinet width | Largeur corps de meuble |  
 Larghezza corpo mobile | Ancho de cuerpo de mueble |  
 Szerokość korpusu

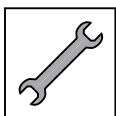

Montage | Assembly | Montage | Montaggio |  
 Montaje | Montaż

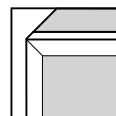

Schmaler Alu Rahmen | Narrow frame | Cadre étroit |  
 Telaio stretto | Marco estrecho | Wąska rama



Einstellung | Adjustment | Adaptation | Adattamento |  
 Adaptación | Nastawienie

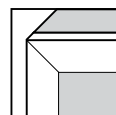

Breiter Alu Rahmen | Wide frame | Cadre large |  
 Telaio largo | Marco ancho | Szeroka rama



Demontage | Removal | Démontage | Smontaggio |  
 Desmontaje | Demontaż

# AVENTOS HS



i

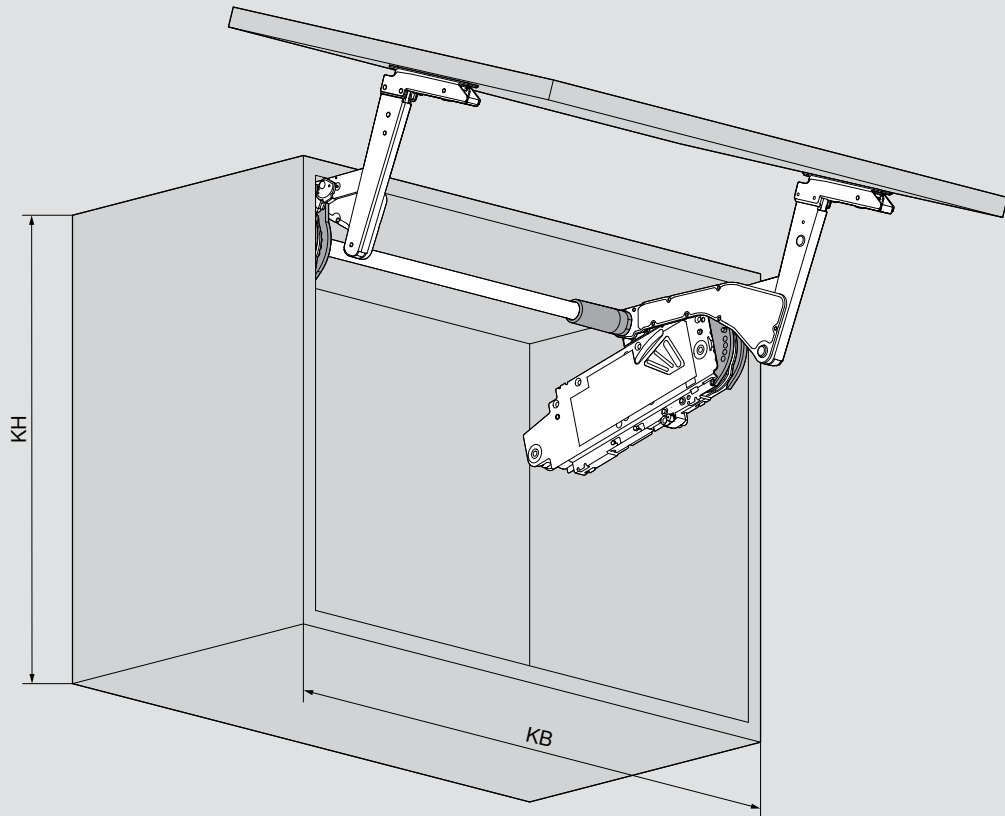

1

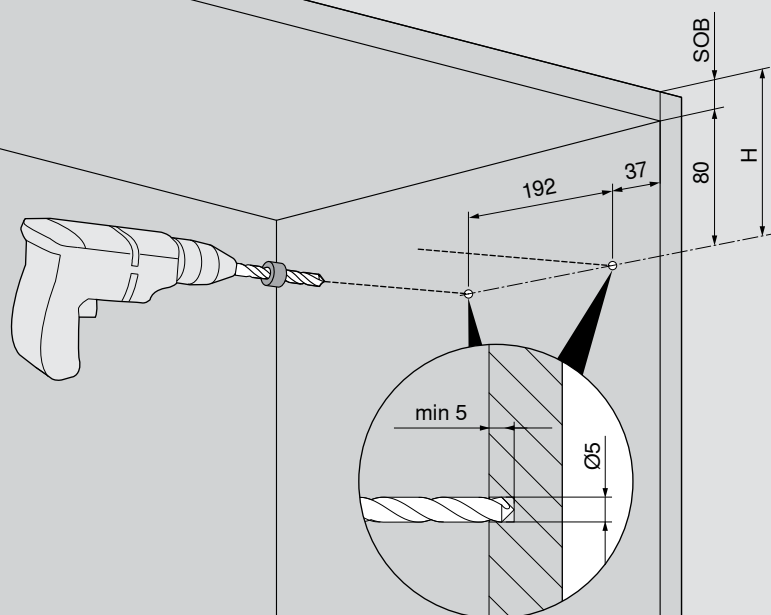

# AVENTOS HS

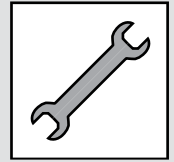
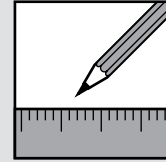

2

2 x

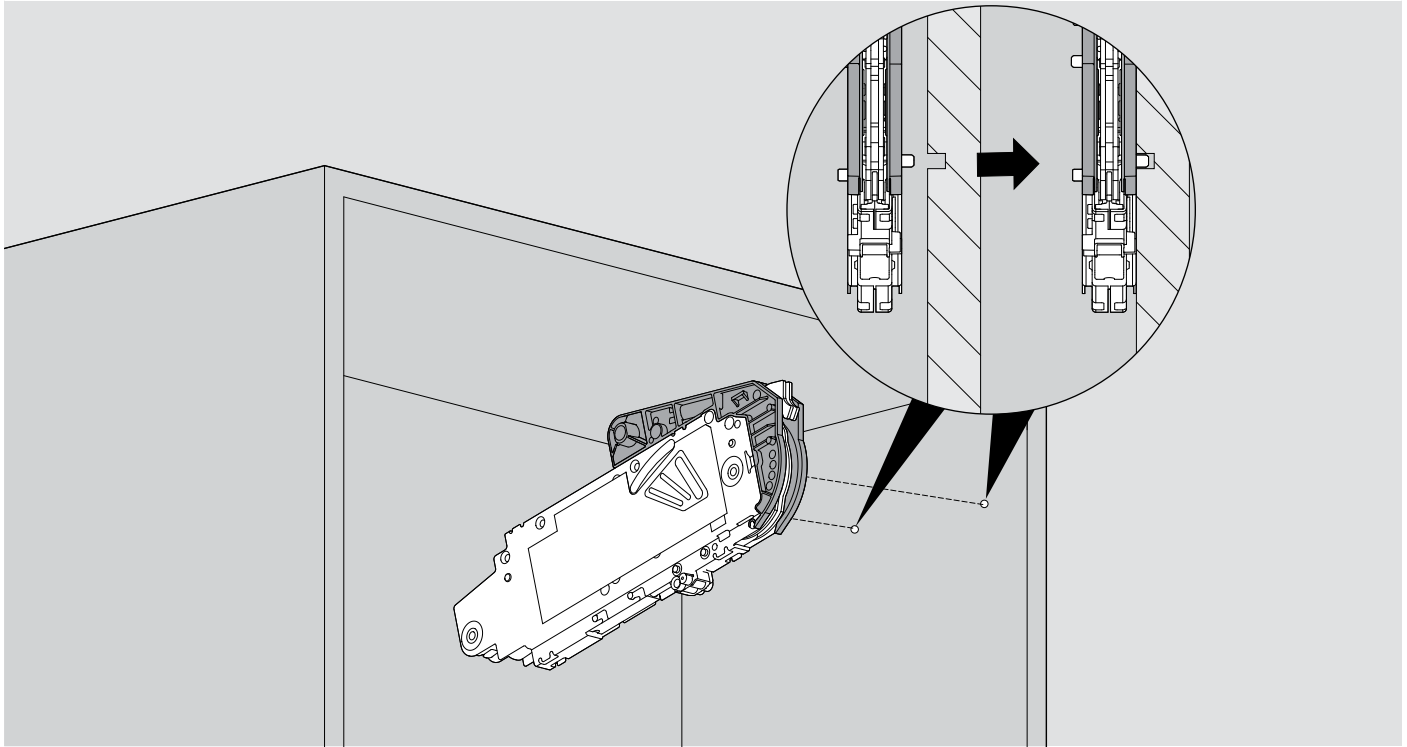
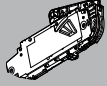

3

10 x  (4 x 35)

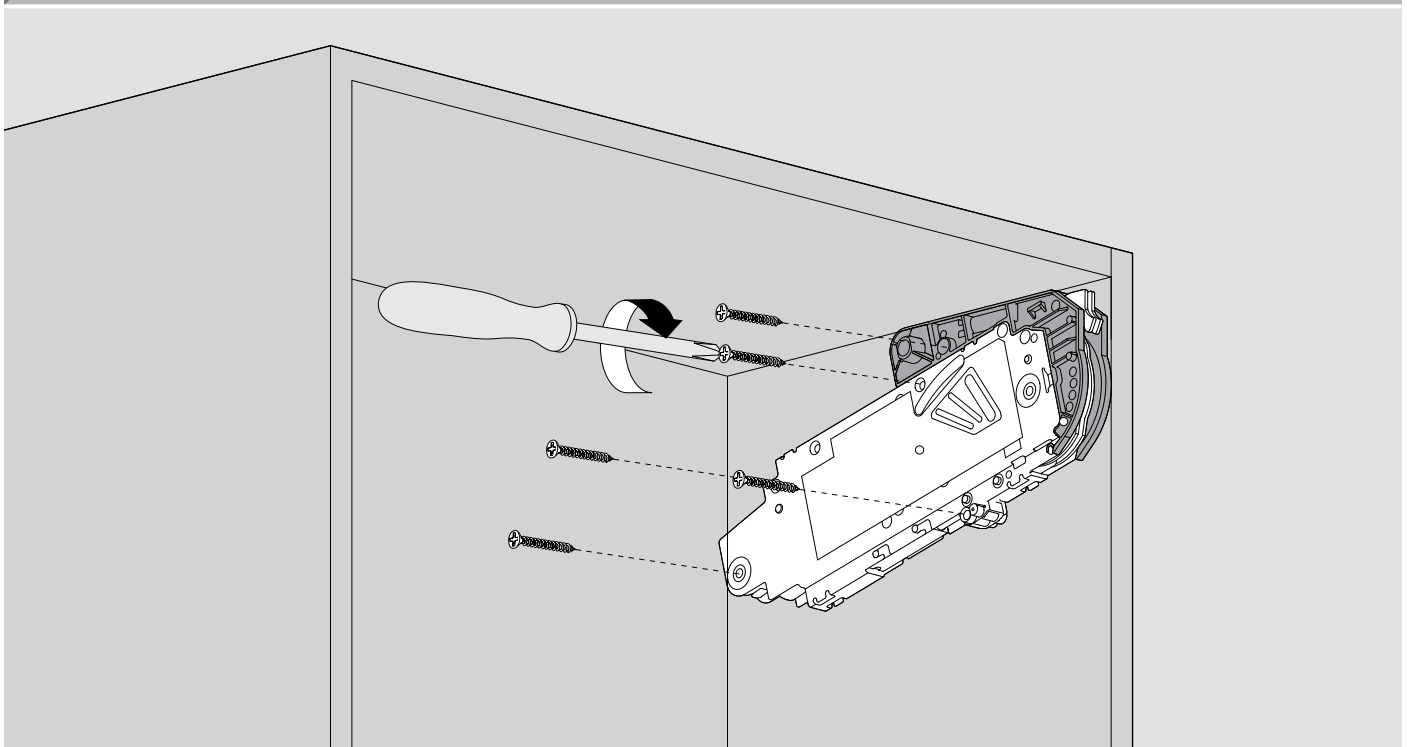



i

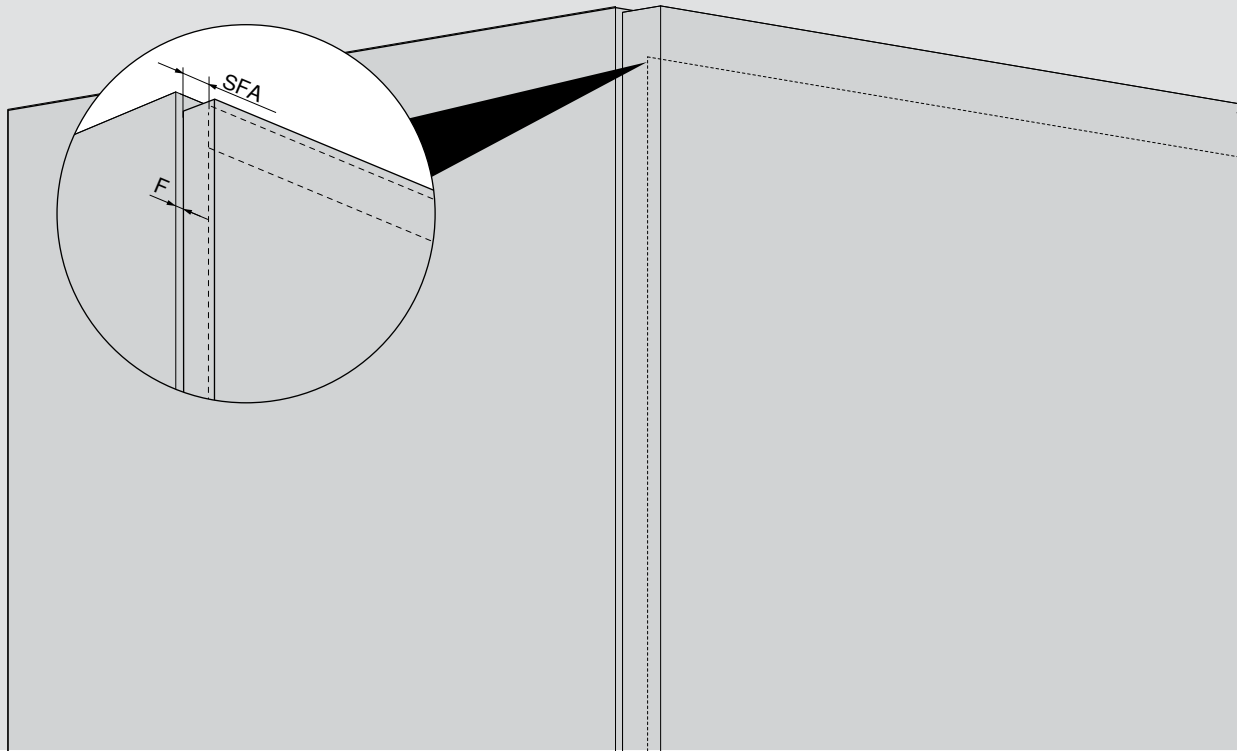

i

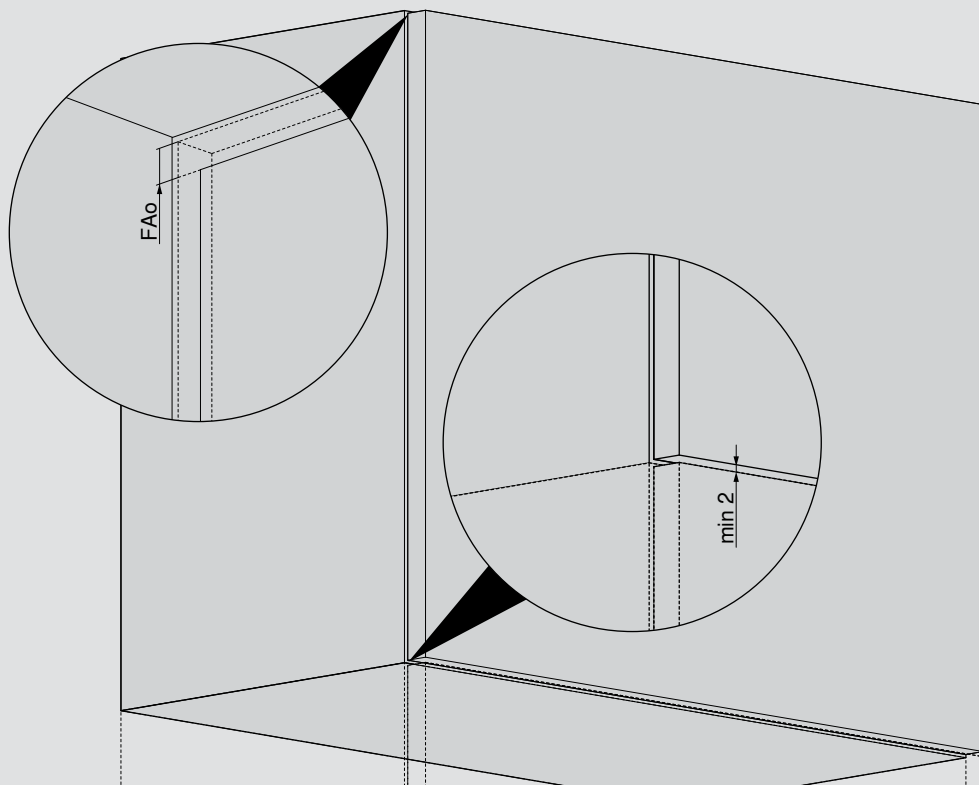

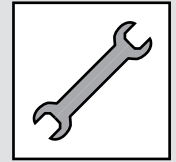
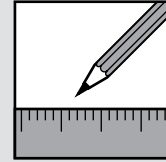

i

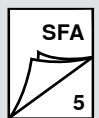
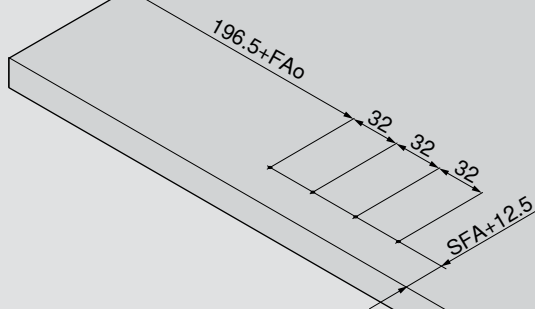

4

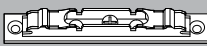
8 x  (3.5 x 15) 2 x 

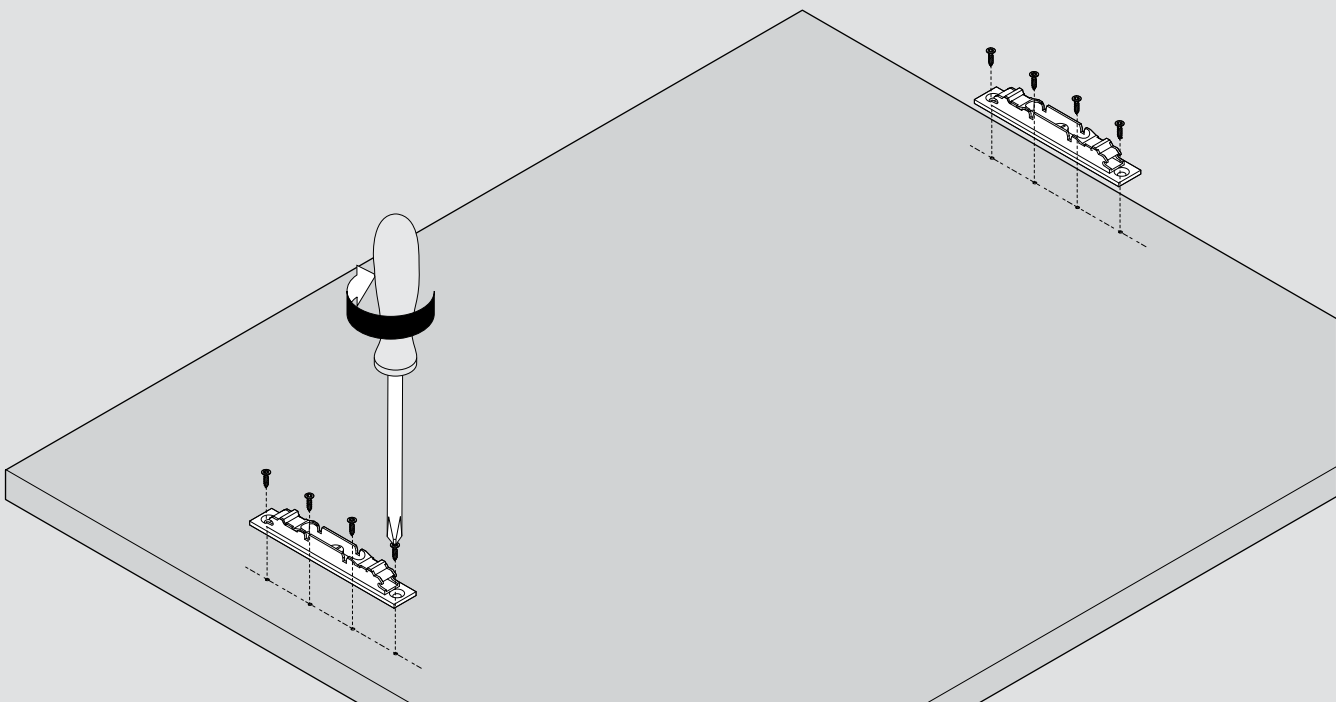

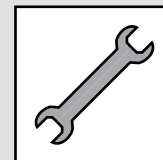

WARNING | WARNING | AVERTISSEMENT | AVVERTENZA |  
 ADVERTENCIA | OSTRZEŻENIE | 警告



Verletzungsgefahr durch hochspringendes Hebelpaket!  
 Risk of injury by spring-loaded lever assembly!  
 Risque de blessure en cas de relevage brusque du pack de bras !  
 Pericolo di lesioni a causa del possibile scatto verso l'alto della  
 pacchetto leve!  
 Peligro de lesiones por salto del brazo.  
 Niebezpieczeństwo zranienia przez gwałtownie unoszący się podnośnik!  
 アーム部分が跳ね上がるとケガをする危険があります

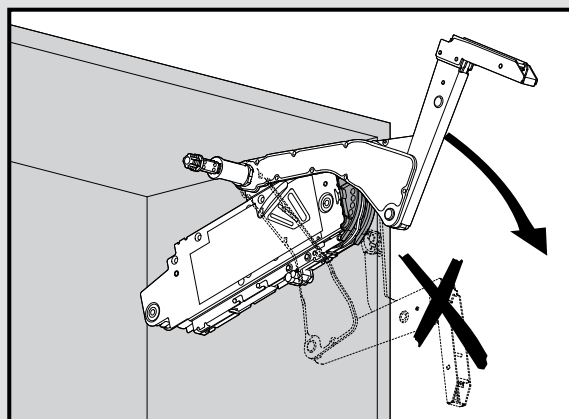

Hebelpaket nicht nach unten drücken, sondern entfernen.  
 Do not push lever assembly down without door attached but remove.  
 Ne pas pousser le pack de bras vers le bas, mais le retirer.  
 Non spingere verso il basso il pacchetto leve, altrimenti rimuoverlo.  
 No apretar el brazo hacia abajo, si no retirarlo.  
 Nie opuszczać podnośnika lecz wyjąć.  
 アーム部分は下に向けて押さえずに外してください。

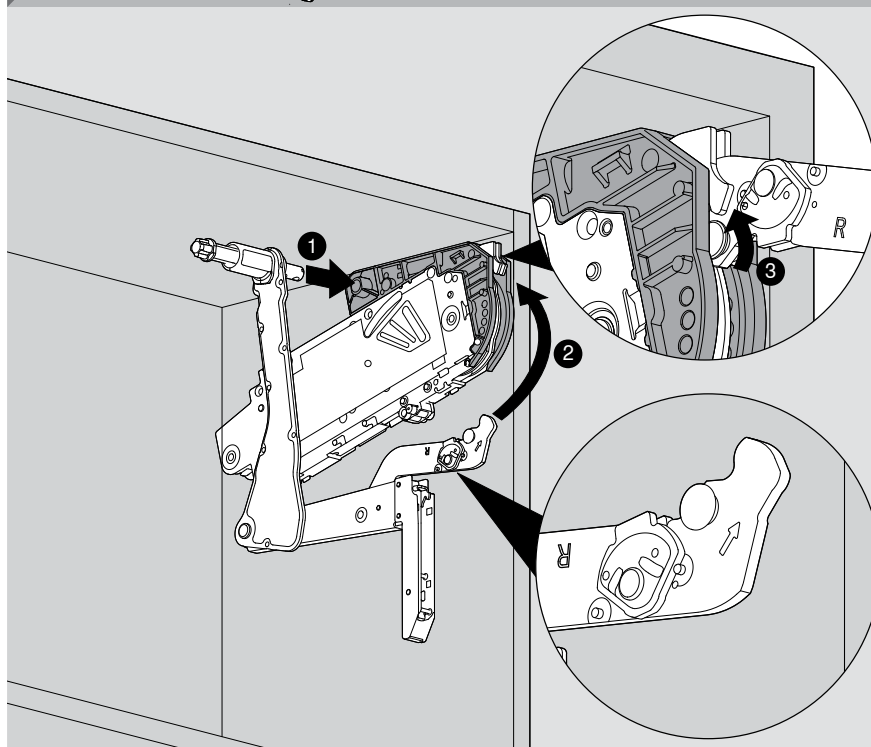



2

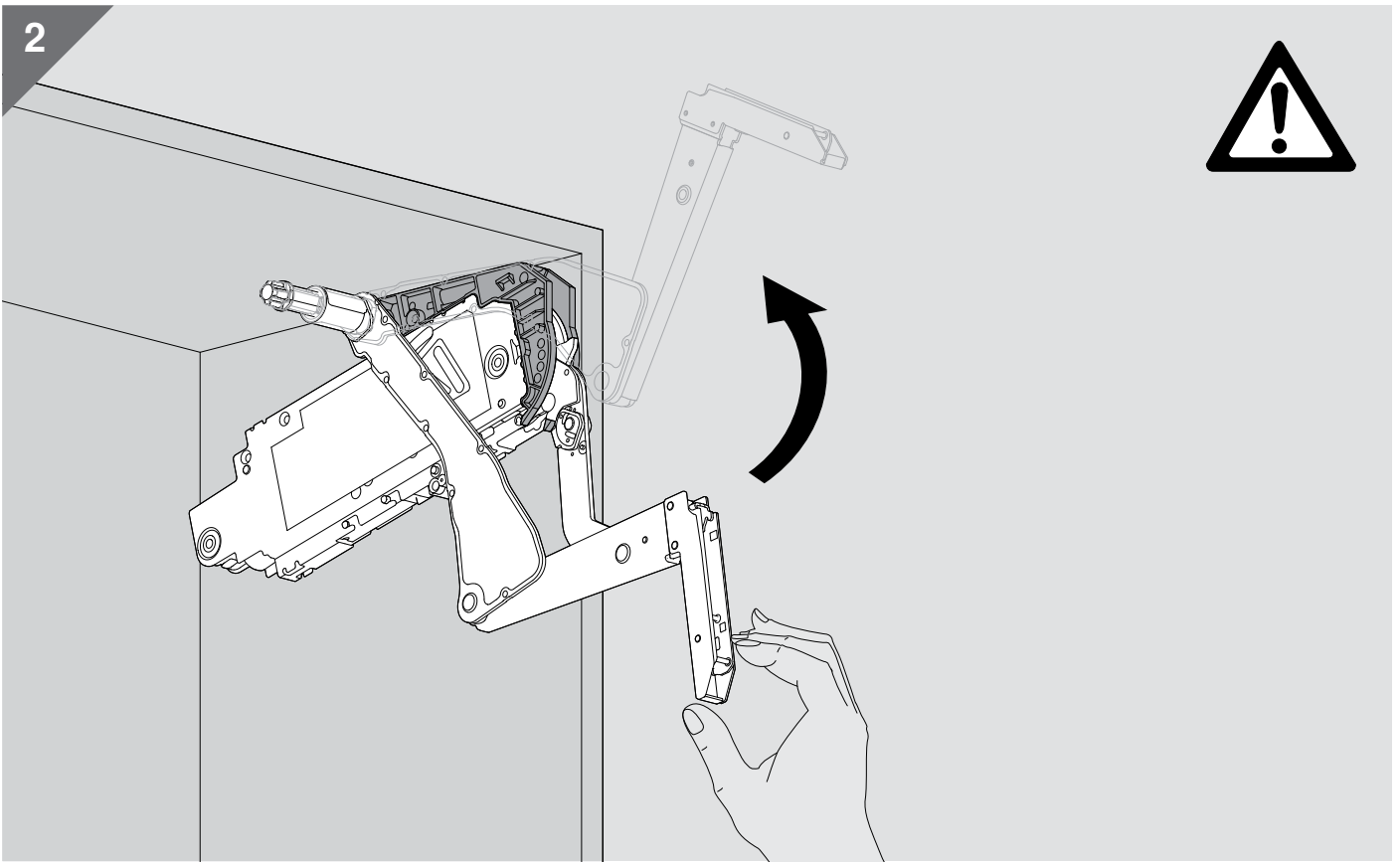

3

1 x

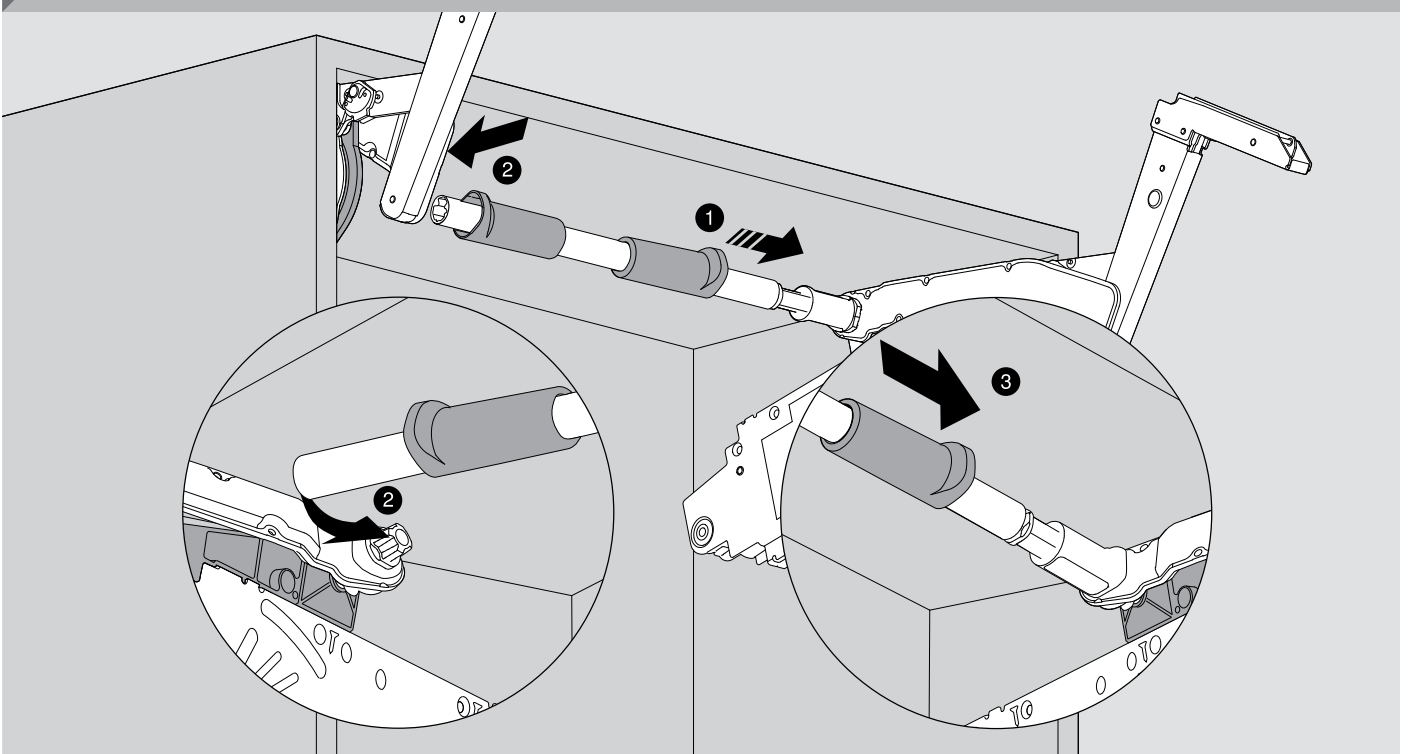
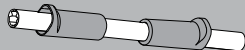



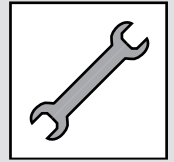

4

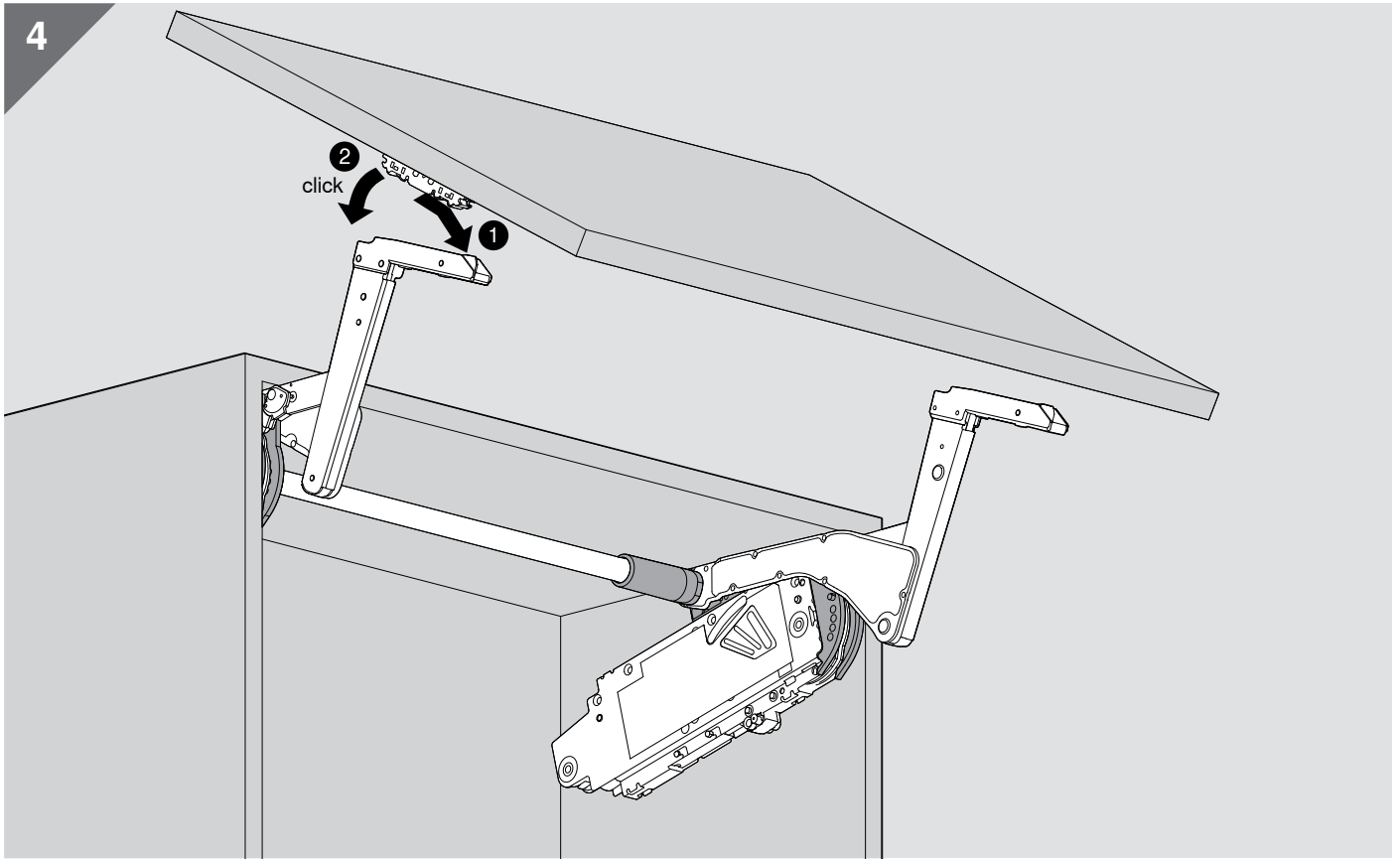

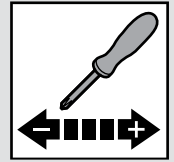
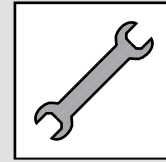

5

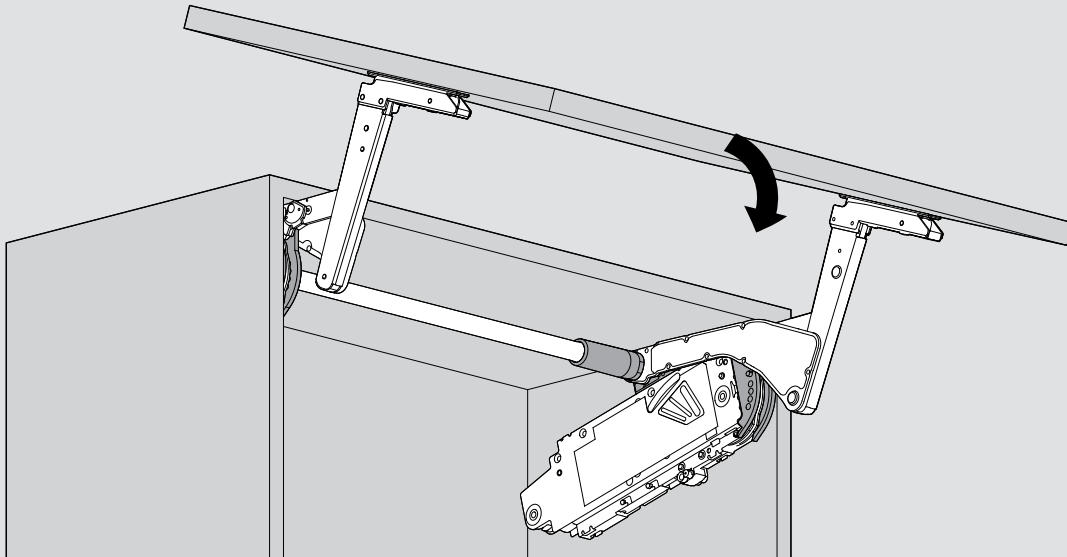

6

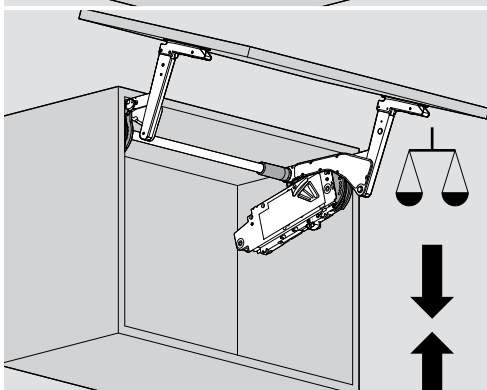
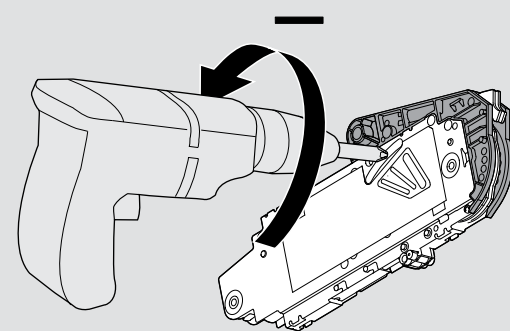
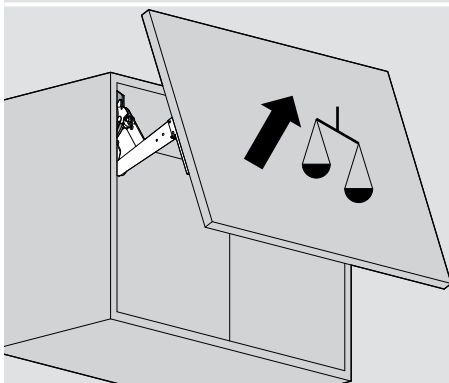
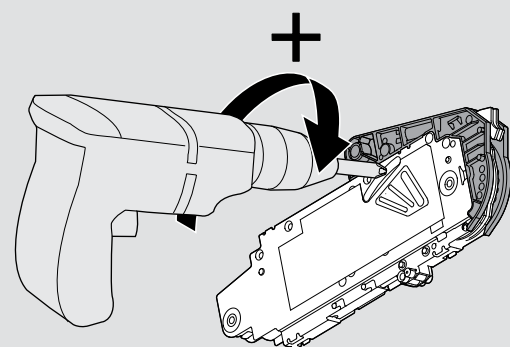
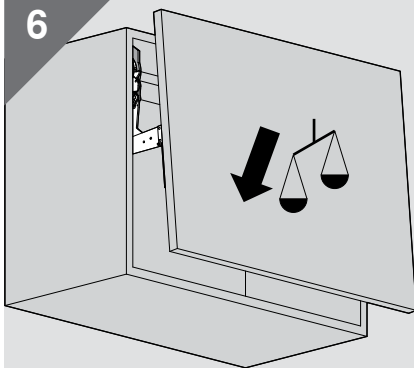

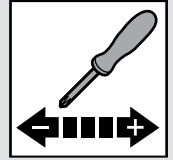

7

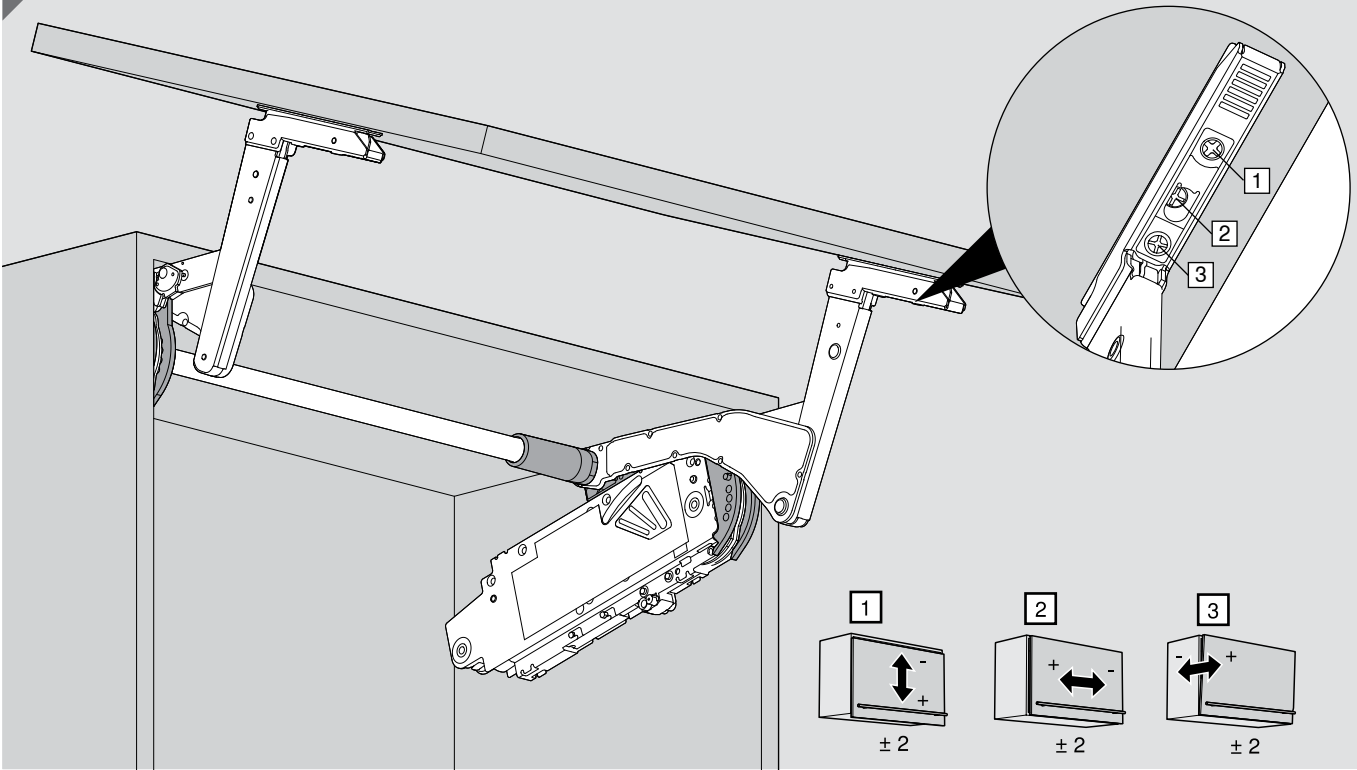

8

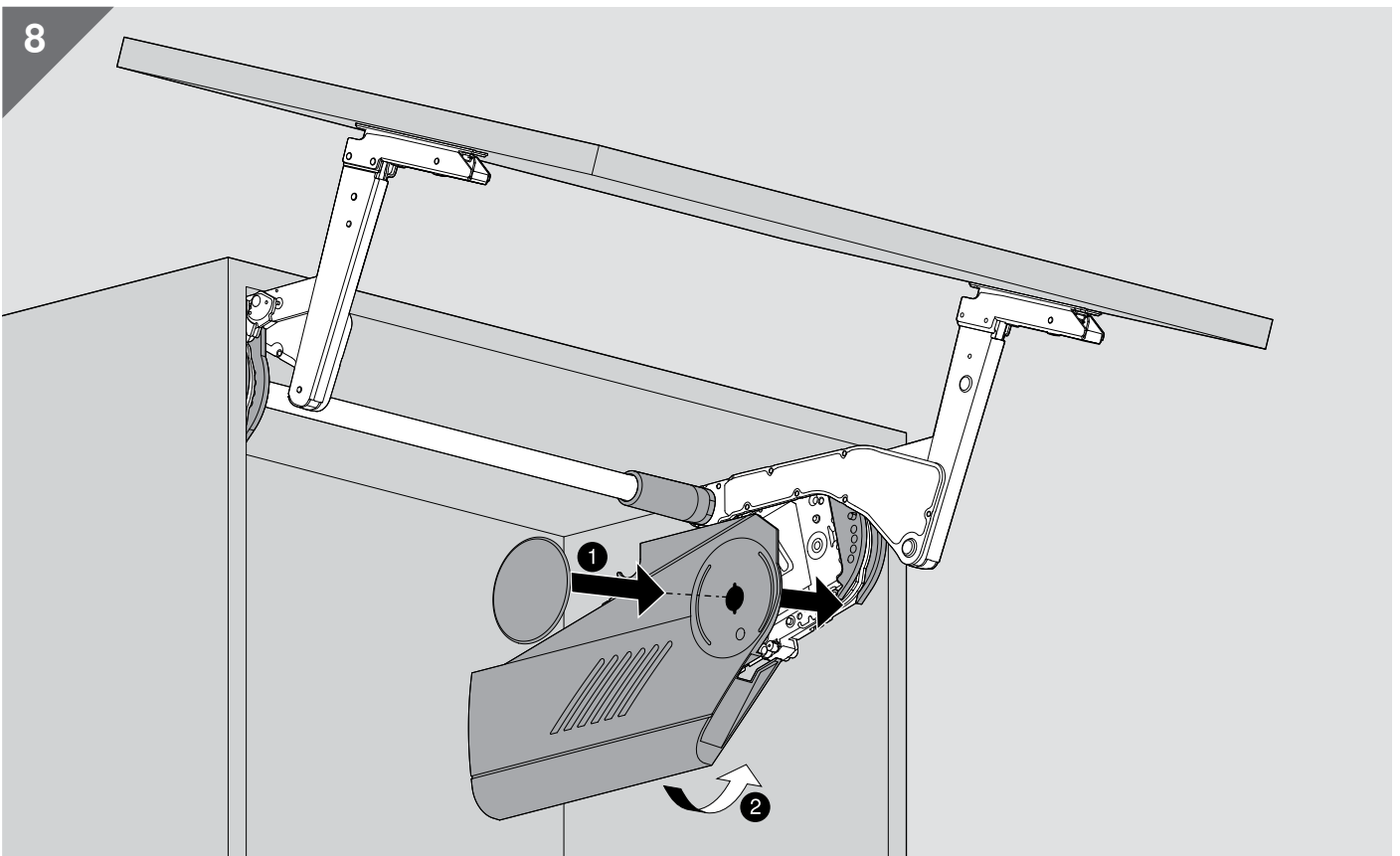

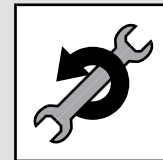

WARNING | WARNING | AVERTISSEMENT | AVVERTENZA |  
ADVERTENCIA | OSTRZEŻENIE | 警告



Verletzungsgefahr durch hochspringendes Hebelpaket!  
Risk of injury by spring-loaded lever assembly!  
Risque de blessure en cas de relevage brusque du pack de bras !  
Pericolo di lesioni a causa del possibile scatto verso l'alto della pacchetto leve!  
Peligro de lesiones por salto del brazo.  
Niebezpieczeństwo zranienia przez gwałtownie unoszący się podnośnik!  
アーム部分が跳ね上がるとケガをする危険があります

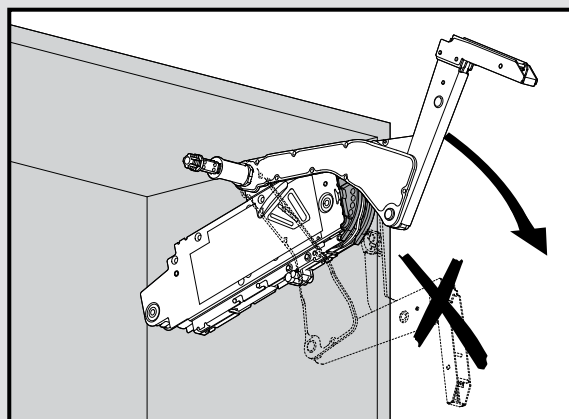

Hebelpaket nicht nach unten drücken, sondern entfernen.  
Do not push lever assembly down without door attached but remove.  
Ne pas pousser le pack de bras vers le bas, mais le retirer.  
Non spingere verso il basso il pacchetto leve, altrimenti rimuoverlo.  
No apretar el brazo hacia abajo, si no retirarlo.  
Nie opuszczać podnośnika lecz wyjąć.  
アーム部分は下に向けて押さえずに外してください。

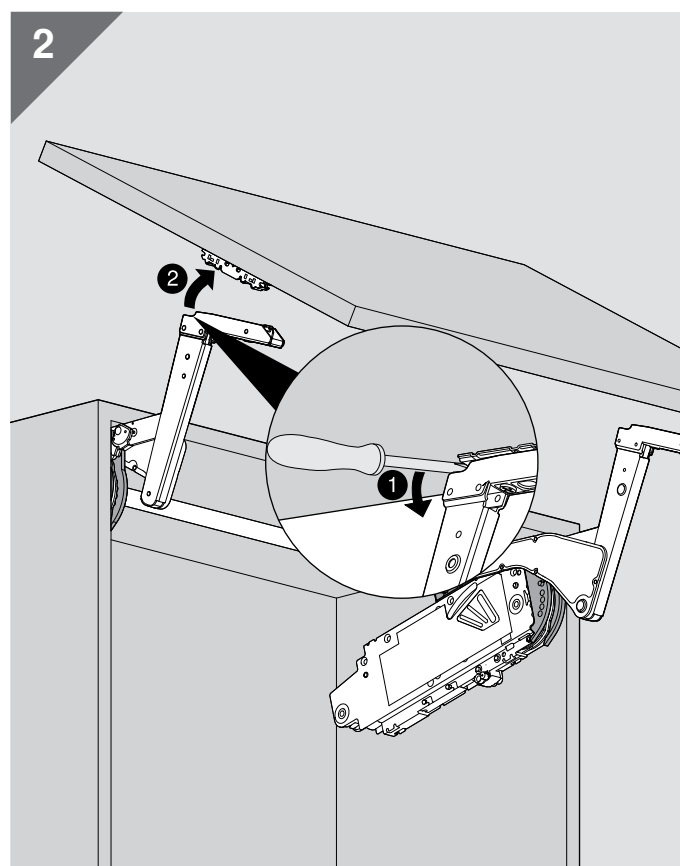
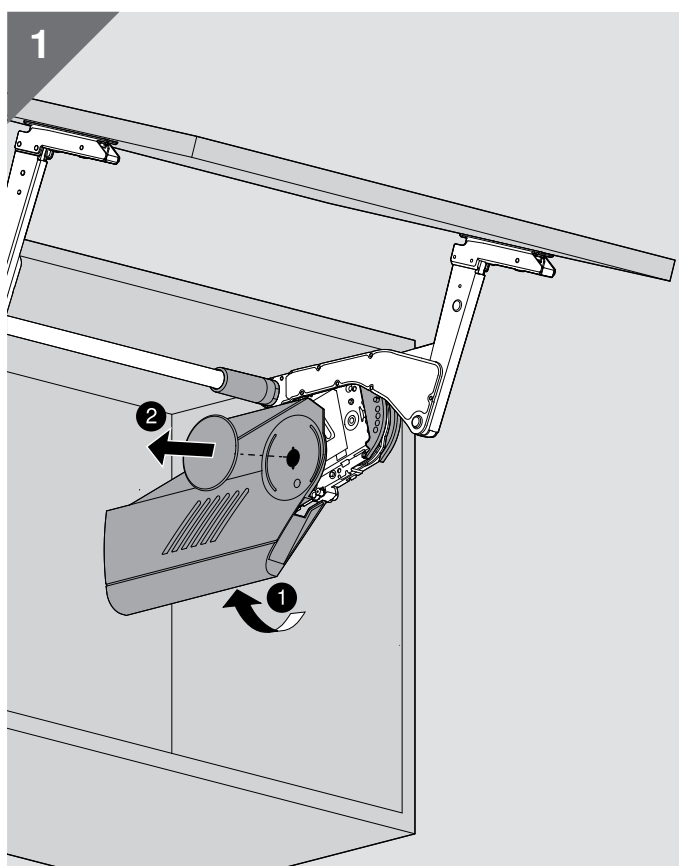

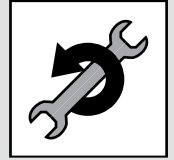

3

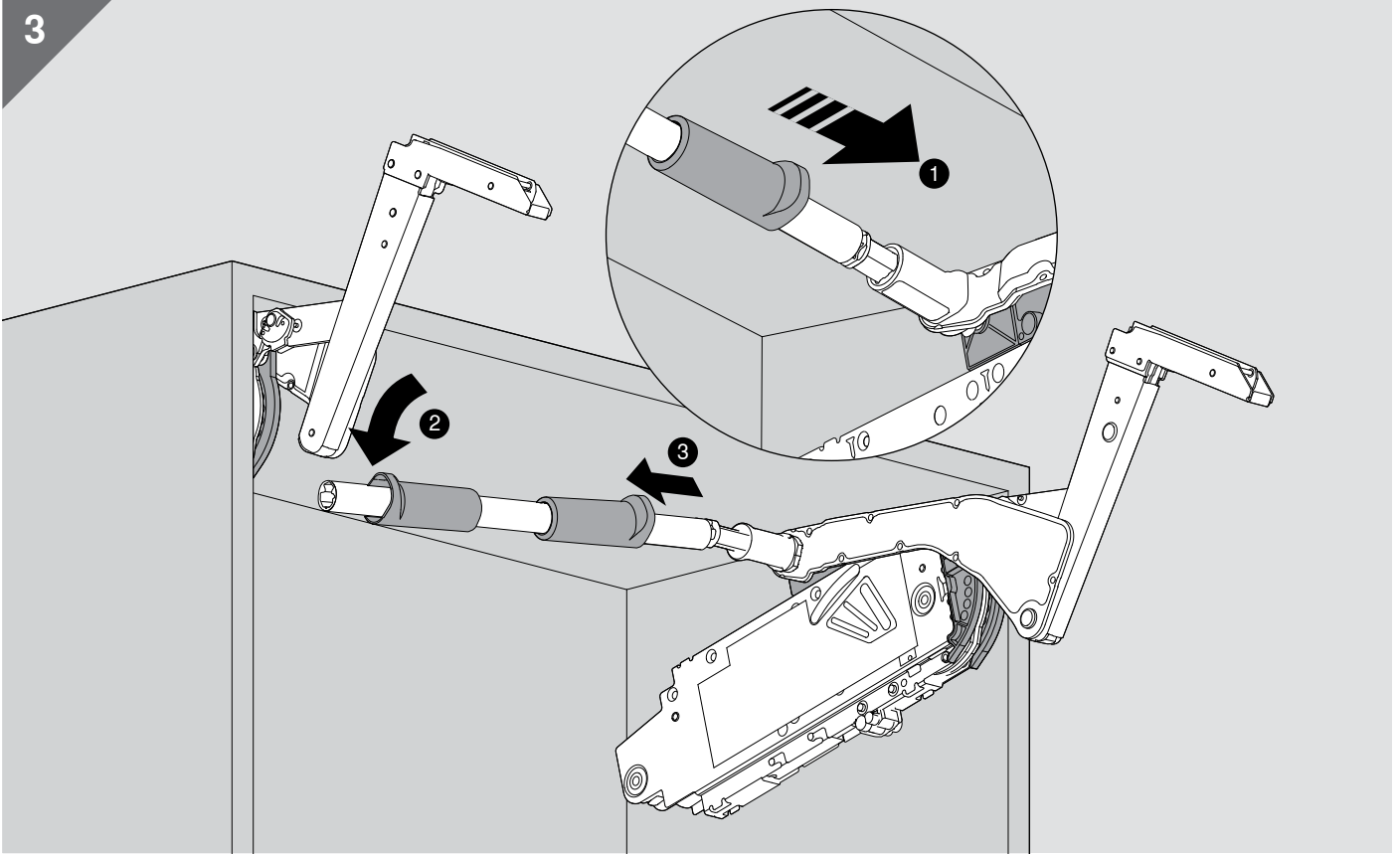

4

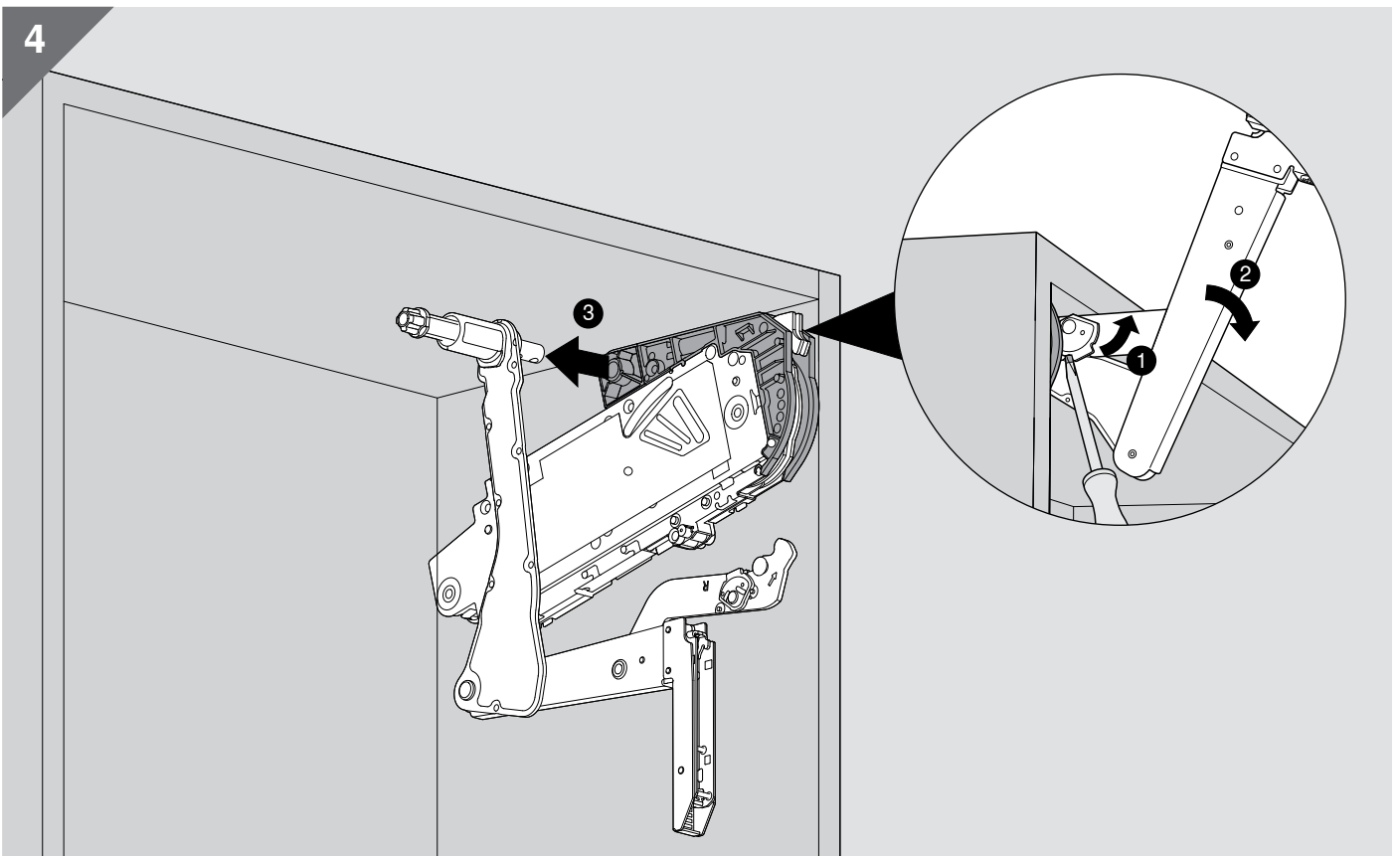

AVENTOS HS





WARNING | WARNING | AVERTISSEMENT |  
AVVERTENZA | ADVERTENCIA | OSTRZEŻENIE |  
警告

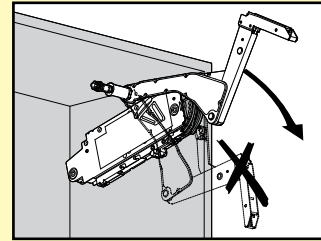
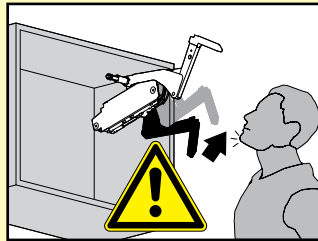

AR	ذراع الرافعة قد يندفع بقوة ويحدث جرح	لا تقوم بدفع الذراع الى اسفل
BG	Опасност от нараняване чрез повдигания пакет!	Повдиганият пакет да не се натиска надолу, а да се отстранява.
CS	Vystřelující ramena jsou zdrojem nebezpečí zranění!	Netlačte ramena směrem dolů, nýbrž je odstraňte.
DA	Risiko for at komme til skade ved opsvingning af løfteanordning.	Løfteanordning må ikke trykkes nedad, men fjernes.
DE	Verletzungsgefahr durch hochspringendes Hebelpaket!	Hebelpaket nicht nach unten drücken, sondern entfernen.
EL	Ο βραχίονας μπορεί να πεταχτεί προς τα επάνω και να προκαλέσει τραυματισμό.	Μην σπρώχνετε προς τα κάτω το βραχίονα.
EN	Risk of injury by spring-loaded lever assembly!	Do not push lever assembly down without door attached but remove.
ES	Peligro de lesiones por salto del brazo.	No apretar el brazo hacia abajo, si no retirarlo.
ET	Kang-hoob võib viskuda üles ja põhjustada trauma.	Ära tõmba alla kang-hooba.
FI	Loukkaantumisvaara – osa voi ponnahtaa ylöspäin!	Osaa ei saa painaa alaspäin, vaan se pitää poistaa.
FR	Risque de blessure en cas de relevage brusque du pack de bras !	Ne pas pousser le pack de bras vers le bas, mais le retirer.
HR	Opasnost od ozljeda uslijed paketa poluga koji iskače!	Paket poluga ne pritišćite prema dolje, već ga uklonite.
HU	Sérülésveszély a felugró teleszkópos emelőkar miatt!	Az emelőkar csomagot ne lefelé nyomja hanem távolítsa el!
IT	Pericolo di lesioni a causa del possibile scatto verso l'alto della pacchetto leve!	Non spingere verso il basso il pacchetto leve, altrimenti rimuoverlo.
IW	זרוע ההרמה עלולה לקפוץ כלפי מעלה ולגרום לפציעה	אסור לדחוף את זרוע ההרמה כלפי מטה
JA	アームが跳ね上がってケガをする可能性があります。	アームを外す時は下に押さないでください。
LT	Svertas gali savaimė atšokti aukštyn ir sužeisti.	Niekada nespaukite žemyn svertą.
LV	Atbalsta svira var strauji atvērties uz augšu un radīt traumu.	Nespiediet uz leju atbalsta sviru.
NL	Risico tot kwetsuren door omhoogspringende hefboom!	Hefboom niet naar onder duwen maar verwijderen.
NO	Kraftig fjærpakke. Fare for skade !	Ikke press løftearmen ned. Demonter før montering av skrog.
PL	Niebezpieczeństwo zranienia przez gwałtownie unoszący się podnośnik!	Nie opuszczają podnośnika lecz wyciąć.
PT	Perigo de ferimento, devido ao brusco salto da alavanca.	A alavanca não deve ser pressionada para baixo mas removida.
RO	Pericol de rănire prin sistemul de pârghii aflat sub tensiunea produsă de arcuri!	Nu apăsați în jos sistemul de pârghii, ci îndepărtați-l.
RU	Существует опасность травмы выскакивающим вверх рычагом!	Не нажимайте рычаг вниз, но снимайте его
SK	Riziko poranenia kvôli vyskakujúcej sústave zdvíhačov!	Sústavu zdvíhačov netlačte smerom dole, ale ich odstráňte.
SL	Nevarnost poškodbe zaradi kompleta ročic, ki lahko odskoči!	Kompleta ročic ne potiskajte navzdol, ampak ga odstranite.
SR	Opasnost od povreda usled iskakajućeg kompleta poluga!	Komplet poluga ne pritiskati nadole, već skinuti.
SV	Skaderisk vid obelastad lyftarmsats!	Tryck inte ned lyftarmsatsen, utan ta bort den.
TR	Kol mekanizması sıçrayabilecek için yaralanma tehlikesi!	Kol mekanizması aşağı doğru bastırılmayıp, çıkarılmalıdır.
UK	Загроза травмування з причини різкого піднімання важільного механізму!	Не опускати до низу важільний механізм. Його необхідно зняти.
ZH	伸縮臂上弹会伤害到人！	请勿下压伸縮臂，请务必取下。